

# Precision, 100µA Gain Selectable Amplifier

## FEATURES

- Pin Configurable as a Difference Amplifier, Inverting and Noninverting Amplifier
- Difference Amplifier
  - Gain Range 1 to 13
  - CMRR >75dB
- Noninverting Amplifier
  - Gain Range 0.07 to 14
- Inverting Amplifier
  - Gain Range -0.08 to -13
- Gain Error <0.04%
- Gain Drift < 3ppm/°C
- Wide Supply Range: Single 2.7V to Split ±18V
- Micropower: 100µA Supply Current
- Precision: 50µV Maximum Input Offset Voltage
- 560kHz Gain Bandwidth Product
- Rail-to-Rail Output
- Space Saving 10-Lead MSOP and DFN Packages

## APPLICATIONS

- Handheld Instrumentation
- Medical Instrumentation
- Strain Gauge Amplifiers
- Differential to Single-Ended Conversion

## DESCRIPTION

The LT®1991 combines a precision operational amplifier with eight precision resistors to form a one-chip solution for accurately amplifying voltages. Gains from -13 to 14 with a gain accuracy of 0.04% can be achieved using no external components. The device is particularly well suited for use as a difference amplifier, where the excellent resistor matching results in a common mode rejection ratio of greater than 75dB.

The amplifier features a 50µV maximum input offset voltage and a gain bandwidth product of 560kHz. The device operates from any supply voltage from 2.7V to 36V and draws only 100µA supply current on a 5V supply. The output swings to within 40mV of either supply rail.

The resistors have excellent matching, 0.04% over temperature for the 450k resistors. The matching temperature coefficient is guaranteed less than 3ppm/°C. The resistors are extremely linear with voltage, resulting in a gain nonlinearity of less than 10ppm.

The LT1991 is fully specified at 5V and ±15V supplies and from -40°C to 125°C. The device is available in space saving 10-lead MSOP and low profile (0.8mm) 3mm × 3mm DFN packages.

LT, LT, LTC and LTM are registered trademarks of Linear Technology Corporation. All other trademarks are the property of their respective owners.

## TYPICAL APPLICATION

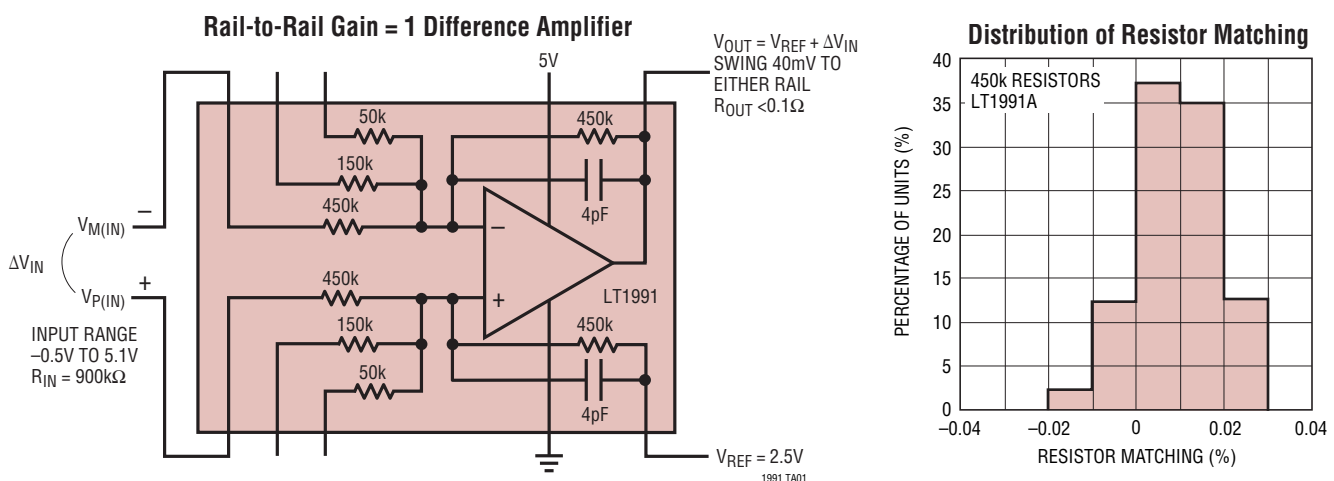

# LT1991

## ABSOLUTE MAXIMUM RATINGS

(Note 1)

Total Supply Voltage ( $V^+$ to $V^-$ ) .....	40V
Input Voltage (Pins P1/M1, Note 2) .....	$\pm 60V$
Input Voltage (Other Inputs Note 2) .....	$V^+ + 0.2V$ to $V^- - 0.2V$
Output Short-Circuit Duration (Note 3) .....	Indefinite
Operating Temperature Range (Note 4)	
LT1991C .....	$-40^\circ\text{C}$ to $85^\circ\text{C}$
LT1991I .....	$-40^\circ\text{C}$ to $85^\circ\text{C}$
LT1991H .....	$-40^\circ\text{C}$ to $125^\circ\text{C}$

Specified Temperature Range (Note 5)

LT1991C .....	$-40^\circ\text{C}$ to $85^\circ\text{C}$
LT1991I .....	$-40^\circ\text{C}$ to $85^\circ\text{C}$
LT1991H .....	$-40^\circ\text{C}$ to $125^\circ\text{C}$

Maximum Junction Temperature

DD Package .....	$125^\circ\text{C}$
MS Package .....	$150^\circ\text{C}$

Storage Temperature Range

DD Package .....	$-65^\circ\text{C}$ to $125^\circ\text{C}$
MS Package .....	$-65^\circ\text{C}$ to $150^\circ\text{C}$

Lead Temperature (Soldering, 10 sec) .....

$300^\circ\text{C}$

## PIN CONFIGURATION

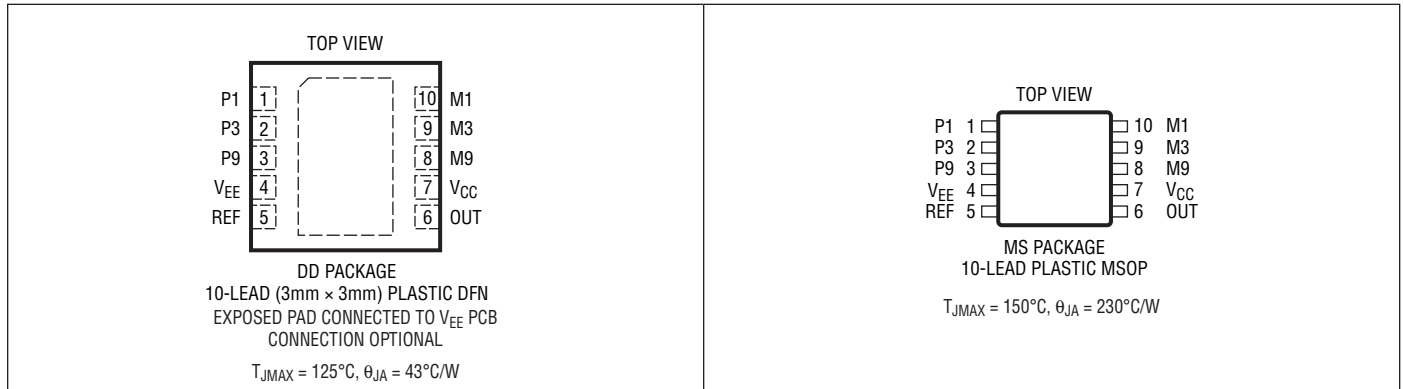

## ORDER INFORMATION

LEAD FREE FINISH	TAPE AND REEL	PART MARKING*	PACKAGE DESCRIPTION	SPECIFIED TEMPERATURE RANGE
LT1991CDD#PBF	LTCT1991CDD#TRPBF	LBMM	10-Lead (3mm x 3mm) Plastic DFN	$0^\circ\text{C}$ to $70^\circ\text{C}$
LT1991ACDD#PBF	LT1991ACDD#TRPBF	LBMM	10-Lead (3mm x 3mm) Plastic DFN	$0^\circ\text{C}$ to $70^\circ\text{C}$
LT1991IDD#PBF	LT1991IDD#TRPBF	LBMM	10-Lead (3mm x 3mm) Plastic DFN	$-40^\circ\text{C}$ to $85^\circ\text{C}$
LT1991AIDD#PBF	LT1991AIDD#TRPBF	LBMM	10-Lead (3mm x 3mm) Plastic DFN	$-40^\circ\text{C}$ to $85^\circ\text{C}$
LT1991HDD#PBF	LT1991HDD#TRPBF	LBMM	10-Lead (3mm x 3mm) Plastic DFN	$-40^\circ\text{C}$ to $125^\circ\text{C}$
LT1991CMS#PBF	LT1991CMS#TRPBF	LTQD	10-Lead Plastic MSOP	$0^\circ\text{C}$ to $70^\circ\text{C}$
LT1991ACMS#PBF	LT1991ACMS#TRPBF	LTQD	10-Lead Plastic MSOP	$0^\circ\text{C}$ to $70^\circ\text{C}$
LT1991IMS#PBF	LT1991IMS#TRPBF	LTQD	10-Lead Plastic MSOP	$-40^\circ\text{C}$ to $85^\circ\text{C}$
LT1991AIMS#PBF	LT1991AIMS#TRPBF	LTQD	10-Lead Plastic MSOP	$-40^\circ\text{C}$ to $85^\circ\text{C}$
LT1991HMS#PBF	LT1991HMS#TRPBF	LTQD	10-Lead Plastic MSOP	$-40^\circ\text{C}$ to $125^\circ\text{C}$

Consult LTC Marketing for parts specified with wider operating temperature ranges. \*Temperature grades are identified by a label on the shipping container. Consult LTC Marketing for information on non-standard lead based finish parts.

For more information on lead free part marking, go to: <http://www.linear.com/leadfree/>

For more information on tape and reel specifications, go to: <http://www.linear.com/tapeandree/>

**ELECTRICAL CHARACTERISTICS** The ● denotes the specifications which apply over the operating temperature range of 0°C to 70°C for C-grade parts and –40°C to 85°C for I-grade parts, otherwise specifications are at T<sub>A</sub> = 25°C. Difference amplifier configuration, V<sub>S</sub> = 5V, 0V or ±15V; V<sub>CM</sub> = V<sub>REF</sub> = half supply, unless otherwise noted.

SYMBOL	PARAMETER	CONDITIONS	MIN	TYP	MAX	UNITS
ΔG	Gain Error	V <sub>S</sub> = ±15V, V <sub>OUT</sub> = ±10V; R <sub>L</sub> = 10k G = 1; LT1991A	●		±0.04	%
		G = 1; LT1991	●		±0.08	%
		G = 3 or 9; LT1991A	●		±0.06	%
		G = 3 or 9; LT1991	●		±0.12	%
GNL	Gain Nonlinearity	V <sub>S</sub> = ±15V; V <sub>OUT</sub> = ±10V; R <sub>L</sub> = 10k	●	1	10	ppm
ΔG/ΔT	Gain Drift vs Temperature (Note 6)	V <sub>S</sub> = ±15V; V <sub>OUT</sub> = ±10V; R <sub>L</sub> = 10k	●	0.3	3	ppm/°C
CMRR	Common Mode Rejection Ratio, Referred to Inputs (RTI)	V <sub>S</sub> = ±15V; V <sub>CM</sub> = ±15.2V G = 9; LT1991A	●	80	100	dB
		G = 3; LT1991A	●	75	93	dB
		G = 1; LT1991A	●	75	90	dB
		Any Gain; LT1991	●	60	70	dB
V <sub>CM</sub>	Input Voltage Range (Note 7)	P1/M1 Inputs V <sub>S</sub> = ±15V; V <sub>REF</sub> = 0V	●	–28	27.6	V
		V <sub>S</sub> = 5V, 0V; V <sub>REF</sub> = 2.5V	●	–0.5	5.1	V
		V <sub>S</sub> = 3V, 0V; V <sub>REF</sub> = 1.25V	●	0.75	2.35	V
		P1/M1 Inputs, P9/M9 Connected to REF V <sub>S</sub> = ±15V; V <sub>REF</sub> = 0V	●	–60	60	V
		V <sub>S</sub> = 5V, 0V; V <sub>REF</sub> = 2.5V	●	–14	16.8	V
		V <sub>S</sub> = 3V, 0V; V <sub>REF</sub> = 1.25V	●	–1.5	7.3	V
		P3/M3 Inputs V <sub>S</sub> = ±15V; V <sub>REF</sub> = 0V	●	–15.2	15.2	V
		V <sub>S</sub> = 5V, 0V; V <sub>REF</sub> = 2.5V	●	0.5	4.2	V
		V <sub>S</sub> = 3V, 0V; V <sub>REF</sub> = 1.25V	●	0.95	1.95	V
		P9/M9 Inputs V <sub>S</sub> = ±15V; V <sub>REF</sub> = 0V	●	–15.2	15.2	V
		V <sub>S</sub> = 5V, 0V; V <sub>REF</sub> = 2.5V	●	0.85	3.9	V
		V <sub>S</sub> = 3V, 0V; V <sub>REF</sub> = 1.25V	●	1.0	1.9	V
V <sub>OS</sub>	Op Amp Offset Voltage (Note 8)	LT1991AMS, V <sub>S</sub> = 5V, 0V	●	15	50 135	μV μV
		LT1991AMS, V <sub>S</sub> = ±15V	●	15	80 160	μV μV
		LT1991MS	●	25	100 200	μV μV
		LT1991DD	●	25	150 250	μV μV
ΔV <sub>OS</sub> /ΔT	Op Amp Offset Voltage Drift (Note 6)		●	0.3	1	μV/°C
I <sub>B</sub>	Op Amp Input Bias Current (Note 11)		●	2.5	5 7.5	nA nA
			●			
I <sub>OS</sub>	Op Amp Input Offset Current (Note 11)	LT1991A	●	50	500 750	pA pA
		LT1991	●	50	1000 1500	pA pA
e <sub>n</sub>	Op Amp Input Noise Voltage	0.01Hz to 1Hz		0.35		μV <sub>P-P</sub>
		0.01Hz to 1Hz		0.07		μV <sub>RMS</sub>
		0.1Hz to 10Hz		0.25		μV <sub>P-P</sub>
		0.1Hz to 10Hz		0.05		μV <sub>RMS</sub>
e <sub>n</sub>	Input Noise Voltage Density	G = 1; f = 1kHz		180		nV/√Hz
		G = 9; f = 1kHz		46		nV/√Hz

## ELECTRICAL CHARACTERISTICS

The ● denotes the specifications which apply over the operating temperature range of 0°C to 70°C for C-grade parts and –40°C to 85°C for I-grade parts, otherwise specifications are at T<sub>A</sub> = 25°C. Difference amplifier configuration, V<sub>S</sub> = 5V, 0V or ±15V; V<sub>CM</sub> = V<sub>REF</sub> = half supply, unless otherwise noted.

SYMBOL	PARAMETER	CONDITIONS	MIN	TYP	MAX	UNITS		
R <sub>IN</sub>	Input Impedance (Note 10)	P1 (M1 = Ground)	●	630	900	1170	kΩ	
		P3 (M3 = Ground)	●	420	600	780	kΩ	
		P9 (M9 = Ground)	●	350	500	650	kΩ	
		M1 (P1 = Ground)	●	315	450	585	kΩ	
		M3 (P3 = Ground)	●	105	150	195	kΩ	
		M9 (P9 = Ground)	●	35	50	65	kΩ	
ΔR	Resistor Matching (Note 9)	450k Resistors, LT1991A	●		0.01	0.04	%	
		Other Resistors, LT1991A	●		0.02	0.06	%	
		450k Resistors, LT1991	●		0.02	0.08	%	
		Other Resistors, LT1991	●		0.04	0.12	%	
ΔR/ΔT	Resistor Temperature Coefficient (Note 6)	Resistor Matching	●		0.3	3	ppm/°C	
		Absolute Value	●		–30		ppm/°C	
PSRR	Power Supply Rejection Ratio	V <sub>S</sub> = ±1.35V to ±18V (Note 8)	●	105	135		dB	
	Minimum Supply Voltage		●		2.4	2.7	V	
V <sub>OUT</sub>	Output Voltage Swing (to Either Rail)	No Load						
		V <sub>S</sub> = 5V, 0V			40	55	mV	
		V <sub>S</sub> = 5V, 0V	●				65	mV
		V <sub>S</sub> = ±15V	●				110	mV
		1mA Load						
		V <sub>S</sub> = 5V, 0V			150	225	mV	
		V <sub>S</sub> = 5V, 0V	●				275	mV
		V <sub>S</sub> = ±15V	●				300	mV
I <sub>SC</sub>	Output Short-Circuit Current (Sourcing)	Drive Output Positive; Short Output to Ground	●	8 4	12		mA mA	
	Output Short-Circuit Current (Sinking)	Drive Output Negative; Short Output to V <sub>S</sub> or Midsupply	●	8 4	21		mA mA	
BW	–3dB Bandwidth	G = 1			110		kHz	
		G = 3			78		kHz	
		G = 9			40		kHz	
GBWP	Op Amp Gain Bandwidth Product	f = 10kHz			560		kHz	
t <sub>r</sub> , t <sub>f</sub>	Rise Time, Fall Time	G = 1; 0.1V Step; 10% to 90%			3		μs	
		G = 9; 0.1V Step; 10% to 90%			8		μs	
t <sub>s</sub>	Settling Time to 0.01%	G = 1; V <sub>S</sub> = 5V, 0V; 2V Step			42		μs	
		G = 1; V <sub>S</sub> = 5V, 0V; –2V Step			48		μs	
		G = 1; V <sub>S</sub> = ±15V, 10V Step			114		μs	
		G = 1; V <sub>S</sub> = ±15V, –10V Step			74		μs	
SR	Slew Rate	V <sub>S</sub> = 5V, 0V; V <sub>OUT</sub> = 1V to 4V	●	0.06	0.12		V/μs	
		V <sub>S</sub> = ±15V; V <sub>OUT</sub> = ±10V; V <sub>MEAS</sub> = ±5V	●	0.08	0.12		V/μs	
I <sub>S</sub>	Supply Current	V <sub>S</sub> = 5V, 0V	●		100	110	μA μA	
		V <sub>S</sub> = ±15V	●		130	160 210	μA μA	

**ELECTRICAL CHARACTERISTICS** The ● denotes the specifications which apply over the operating temperature range of  $-40^{\circ}\text{C}$  to  $125^{\circ}\text{C}$  for H-grade parts, otherwise specifications are at  $T_A = 25^{\circ}\text{C}$ . Difference amplifier configuration,  $V_S = 5\text{V}$ ,  $0\text{V}$  or  $\pm 15\text{V}$ ;  $V_{\text{CM}} = V_{\text{REF}} = \text{half supply}$ , unless otherwise noted.

SYMBOL	PARAMETER	CONDITIONS	MIN	TYP	MAX	UNITS	
$\Delta G$	Gain Error	$V_S = \pm 15\text{V}$ , $V_{\text{OUT}} = \pm 10\text{V}$ ; $R_L = 10\text{k}$ $G = 1$	●		$\pm 0.08$	%	
		$G = 3$ or $9$	●		$\pm 0.12$	%	
GNL	Gain Nonlinearity	$V_S = \pm 15\text{V}$ ; $V_{\text{OUT}} = \pm 10\text{V}$ ; $R_L = 10\text{k}$	●	1	10	ppm	
$\Delta G/\Delta T$	Gain Drift vs Temperature (Note 6)	$V_S = \pm 15\text{V}$ ; $V_{\text{OUT}} = \pm 10\text{V}$ ; $R_L = 10\text{k}$	●	0.3	3	ppm/ $^{\circ}\text{C}$	
CMRR	Common Mode Rejection Ratio, Referred to Inputs (RTI)	$V_S = \pm 15\text{V}$ ; $V_{\text{CM}} = \pm 15.2\text{V}$ $G = 9$	●	77	100	dB	
		$G = 3$	●	70	93	dB	
		$G = 1$	●	70	90	dB	
$V_{\text{CM}}$	Input Voltage Range (Note 7)	P1/M1 Inputs $V_S = \pm 15\text{V}$ ; $V_{\text{REF}} = 0\text{V}$	●	-28	27.6	V	
		$V_S = 5\text{V}$ , $0\text{V}$ ; $V_{\text{REF}} = 2.5\text{V}$	●	-0.5	5.1	V	
		$V_S = 3\text{V}$ , $0\text{V}$ ; $V_{\text{REF}} = 1.25\text{V}$	●	0.75	2.35	V	
		P1/M1 Inputs, P9/M9 Connected to REF $V_S = \pm 15\text{V}$ ; $V_{\text{REF}} = 0\text{V}$	●	-60	60	V	
		$V_S = 5\text{V}$ , $0\text{V}$ ; $V_{\text{REF}} = 2.5\text{V}$	●	-14	16.8	V	
		$V_S = 3\text{V}$ , $0\text{V}$ ; $V_{\text{REF}} = 1.25\text{V}$	●	-1.5	7.3	V	
		P3/M3 Inputs $V_S = \pm 15\text{V}$ ; $V_{\text{REF}} = 0\text{V}$	●	-15.2	15.2	V	
		$V_S = 5\text{V}$ , $0\text{V}$ ; $V_{\text{REF}} = 2.5\text{V}$	●	0.5	4.2	V	
		$V_S = 3\text{V}$ , $0\text{V}$ ; $V_{\text{REF}} = 1.25\text{V}$	●	0.95	1.95	V	
		P9/M9 Inputs $V_S = \pm 15\text{V}$ ; $V_{\text{REF}} = 0\text{V}$	●	-15.2	15.2	V	
		$V_S = 5\text{V}$ , $0\text{V}$ ; $V_{\text{REF}} = 2.5\text{V}$	●	0.85	3.9	V	
		$V_S = 3\text{V}$ , $0\text{V}$ ; $V_{\text{REF}} = 1.25\text{V}$	●	1.0	1.9	V	
$V_{\text{OS}}$	Op Amp Offset Voltage (Note 8)	LT1991MS	●	25	100 285	$\mu\text{V}$ $\mu\text{V}$	
		LT1991DD	●	25	150 295	$\mu\text{V}$ $\mu\text{V}$	
$\Delta V_{\text{OS}}/\Delta T$	Op Amp Offset Voltage Drift (Note 6)		●	0.3	1	$\mu\text{V}/^{\circ}\text{C}$	
IB	Op Amp Input Bias Current (Note 11)		●	2.5	5 25	nA nA	
			●	50	1000 4500	pA pA	
	Op Amp Input Noise Voltage	0.01Hz to 1Hz		0.35		$\mu\text{V}_{\text{P-P}}$	
		0.01Hz to 1Hz		0.07		$\mu\text{V}_{\text{RMS}}$	
		0.1Hz to 10Hz		0.25		$\mu\text{V}_{\text{P-P}}$	
		0.1Hz to 10Hz		0.05		$\mu\text{V}_{\text{RMS}}$	
$e_n$	Input Noise Voltage Density	$G = 1$ ; $f = 1\text{kHz}$		180		$\text{nV}/\sqrt{\text{Hz}}$	
		$G = 9$ ; $f = 1\text{kHz}$		46		$\text{nV}/\sqrt{\text{Hz}}$	
$R_{\text{IN}}$	Input Impedance (Note 10)	P1 (M1 = Ground)	●	630	900	1170	k $\Omega$
		P3 (M3 = Ground)	●	420	600	780	k $\Omega$
		P9 (M9 = Ground)	●	350	500	650	k $\Omega$
		M1 (P1 = Ground)	●	315	450	585	k $\Omega$
		M3 (P3 = Ground)	●	105	150	195	k $\Omega$
		M9 (P9 = Ground)	●	35	50	65	k $\Omega$
$\Delta R$	Resistor Matching (Note 9)	450k Resistors	●	0.02	0.08	%	
		Other Resistors	●	0.04	0.12	%	
$\Delta R/\Delta T$	Resistor Temperature Coefficient (Note 6)	Resistor Matching	●	0.3	3	ppm/ $^{\circ}\text{C}$	
		Absolute Value	●	-30		ppm/ $^{\circ}\text{C}$	

## ELECTRICAL CHARACTERISTICS

The ● denotes the specifications which apply over the operating temperature range of  $-40^{\circ}\text{C}$  to  $125^{\circ}\text{C}$  for H-grade parts, otherwise specifications are at  $T_A = 25^{\circ}\text{C}$ . Difference amplifier configuration,  $V_S = 5\text{V}$ ,  $0\text{V}$  or  $\pm 15\text{V}$ ;  $V_{\text{CM}} = V_{\text{REF}} = \text{half supply}$ , unless otherwise noted.

SYMBOL	PARAMETER	CONDITIONS	MIN	TYP	MAX	UNITS
PSRR	Power Supply Rejection Ratio	$V_S = \pm 1.35\text{V}$ to $\pm 18\text{V}$ (Note 8)	●	105	135	dB
	Minimum Supply Voltage		●	2.4	2.7	V
$V_{\text{OUT}}$	Output Voltage Swing (to Either Rail)	No Load				
		$V_S = 5\text{V}$ , $0\text{V}$	●	40	55	mV
		$V_S = 5\text{V}$ , $0\text{V}$	●		75	mV
		$V_S = \pm 15\text{V}$	●		120	mV
$I_{\text{SC}}$	Output Short-Circuit Current (Sourcing)	1mA Load				
		$V_S = 5\text{V}$ , $0\text{V}$	●	150	225	mV
		$V_S = 5\text{V}$ , $0\text{V}$	●		300	mV
		$V_S = \pm 15\text{V}$	●		340	mV
$I_{\text{SC}}$	Output Short-Circuit Current (Sinking)	Drive Output Positive; Short Output to Ground	●	8	12	mA
		Drive Output Negative; Short Output to $V_S$ or Midsupply	●	4	21	mA
BW	-3dB Bandwidth	$G = 1$				kHz
		$G = 3$				kHz
		$G = 9$				kHz
GBWP	Op Amp Gain Bandwidth Product	$f = 10\text{kHz}$		560		kHz
$t_r$ , $t_f$	Rise Time, Fall Time	$G = 1$ ; $0.1\text{V}$ Step; 10% to 90%		3		$\mu\text{s}$
		$G = 9$ ; $0.1\text{V}$ Step; 10% to 90%		8		$\mu\text{s}$
$t_s$	Settling Time to 0.01%	$G = 1$ ; $V_S = 5\text{V}$ , $0\text{V}$ ; $2\text{V}$ Step		42		$\mu\text{s}$
		$G = 1$ ; $V_S = 5\text{V}$ , $0\text{V}$ ; $-2\text{V}$ Step		48		$\mu\text{s}$
		$G = 1$ ; $V_S = \pm 15\text{V}$ , $10\text{V}$ Step		114		$\mu\text{s}$
		$G = 1$ ; $V_S = \pm 15\text{V}$ , $-10\text{V}$ Step		74		$\mu\text{s}$
SR	Slew Rate	$V_S = 5\text{V}$ , $0\text{V}$ ; $V_{\text{OUT}} = 1\text{V}$ to $4\text{V}$	●	0.06	0.12	$\text{V}/\mu\text{s}$
		$V_S = \pm 15\text{V}$ ; $V_{\text{OUT}} = \pm 10\text{V}$ ; $V_{\text{MEAS}} = \pm 5\text{V}$	●	0.08	0.12	$\text{V}/\mu\text{s}$
$I_S$	Supply Current	$V_S = 5\text{V}$ , $0\text{V}$	●	100	110	$\mu\text{A}$
					180	$\mu\text{A}$
		$V_S = \pm 15\text{V}$	●	130	160	$\mu\text{A}$
				250	$\mu\text{A}$	

**Note 1:** Stresses beyond those listed under Absolute Maximum Ratings may cause permanent damage to the device. Exposure to any Absolute Maximum Rating condition for extended periods may affect device reliability and lifetime.

**Note 2:** The P3/M3 and P9/M9 inputs should not be taken more than 0.2V beyond the supply rails. The P1/M1 inputs can withstand  $\pm 60\text{V}$  if P9/M9 are grounded and  $V_S = \pm 15\text{V}$  (see Applications Information section about "High Voltage CM Difference Amplifiers").

**Note 3:** A heat sink may be required to keep the junction temperature below absolute maximum ratings.

**Note 4:** Both the LT1991C and LT1991I are guaranteed functional over the  $-40^{\circ}\text{C}$  to  $85^{\circ}\text{C}$  temperature range. The LTC1991H is guaranteed functional over the  $-40^{\circ}\text{C}$  to  $125^{\circ}\text{C}$  temperature range.

**Note 5:** The LT1991C is guaranteed to meet the specified performance from  $0^{\circ}\text{C}$  to  $70^{\circ}\text{C}$  and is designed, characterized and expected to meet specified performance from  $-40^{\circ}\text{C}$  to  $85^{\circ}\text{C}$  but is not tested or QA sampled at these temperatures. The LT1991I is guaranteed to meet specified performance from  $-40^{\circ}\text{C}$  to  $85^{\circ}\text{C}$ . The LT1991H is guaranteed to meet specified performance from  $-40^{\circ}\text{C}$  to  $125^{\circ}\text{C}$ .

**Note 6:** This parameter is not 100% tested.

**Note 7:** Input voltage range is guaranteed by the CMRR test at  $V_S = \pm 15\text{V}$ . For the other voltages, this parameter is guaranteed by design and through correlation with the  $\pm 15\text{V}$  test. See the Applications Information section to determine the valid input voltage range under various operating conditions.

**Note 8:** Offset voltage, offset voltage drift and PSRR are defined as referred to the internal op amp. You can calculate output offset as follows. In the case of balanced source resistance,  $V_{\text{OS,OUT}} = V_{\text{OS}} \cdot \text{NOISEGAIN} + I_{\text{OS}} \cdot 450\text{k} + I_{\text{B}} \cdot 450\text{k} \cdot (1 - R_{\text{P}}/R_{\text{N}})$  where  $R_{\text{P}}$  and  $R_{\text{N}}$  are the total resistance at the op amp positive and negative terminal respectively.

**Note 9:** Applies to resistors that are connected to the inverting inputs. Resistor matching is not tested directly, but is guaranteed by the gain error test.

**Note 10:** Input impedance is tested by a combination of direct measurements and correlation to the CMRR and gain error tests.

**Note 11:**  $I_{\text{B}}$  and  $I_{\text{OS}}$  are tested at  $V_S = 5\text{V}$ ,  $0\text{V}$  only.

# TYPICAL PERFORMANCE CHARACTERISTICS (Difference Amplifier Configuration)

**Supply Current vs Supply Voltage**

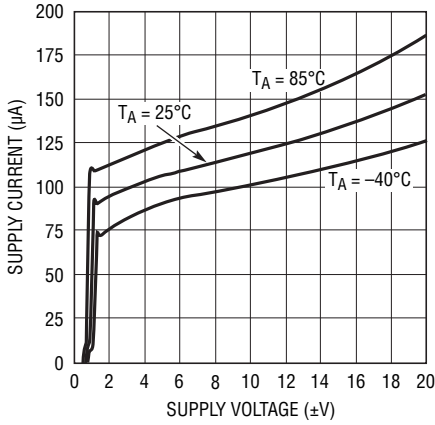

1991 G01

**Output Voltage Swing vs Temperature**

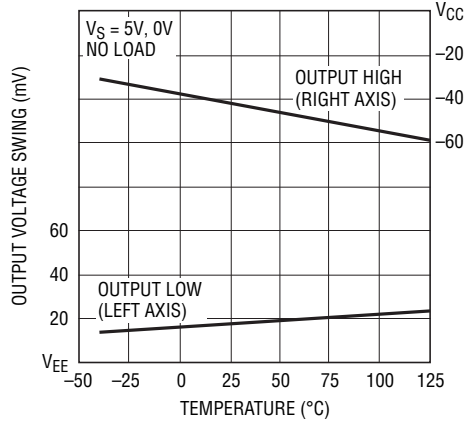

1991 G02

**Output Voltage Swing vs Load Current (Output Low)**

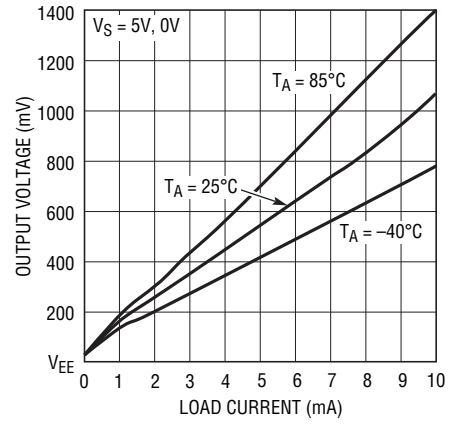

1991 G03

**Output Voltage Swing vs Load Current (Output High)**

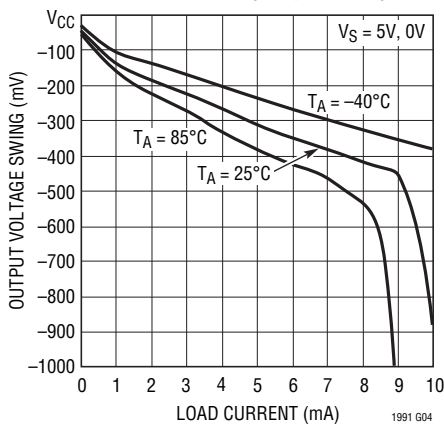

1991 G04

**Output Short-Circuit Current vs Temperature**

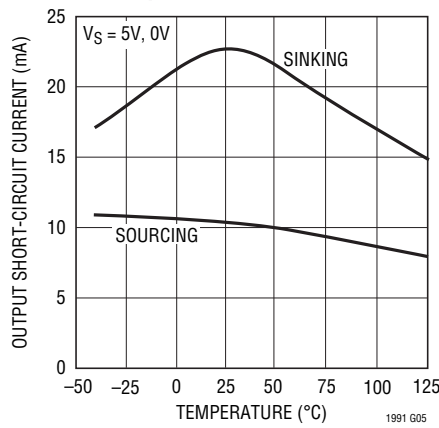

1991 G05

**Input Offset Voltage vs Difference Gain**

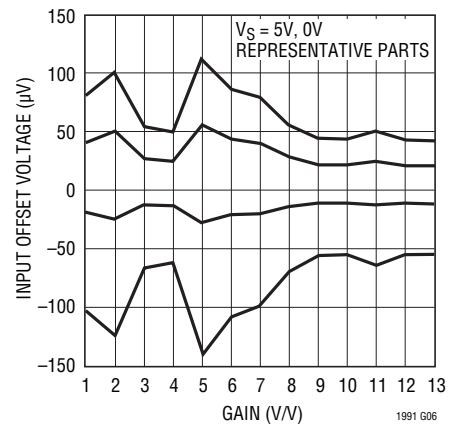

1991 G06

**Output Offset Voltage vs Difference Gain**

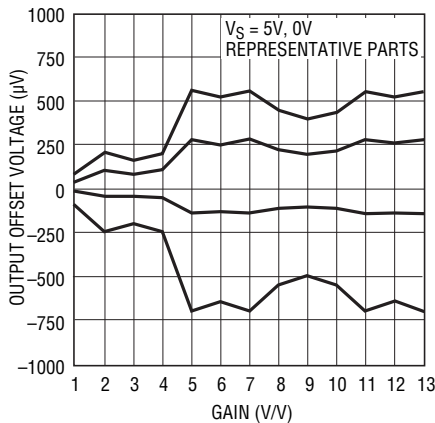

1991 G07

**Gain Error vs Load Current**

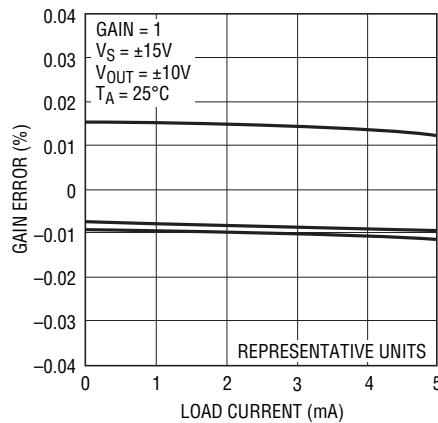

1991 G08

**Slew Rate vs Temperature**

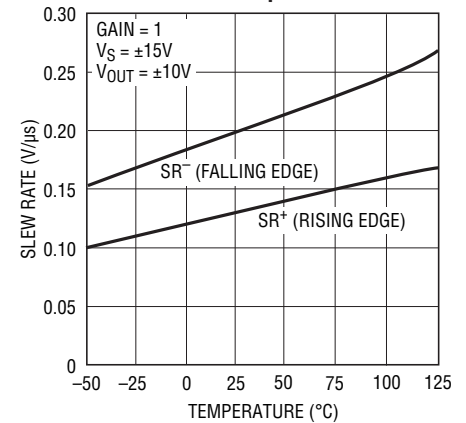

1991 G09

**TYPICAL PERFORMANCE CHARACTERISTICS** (Difference Amplifier Configuration)

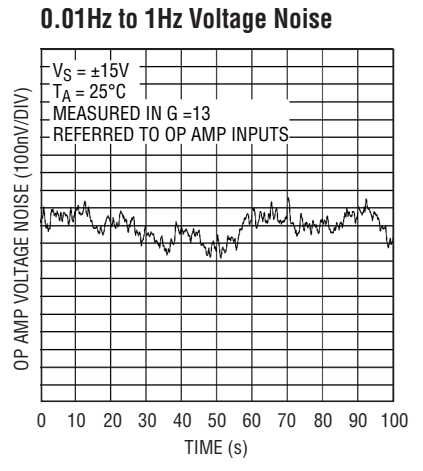
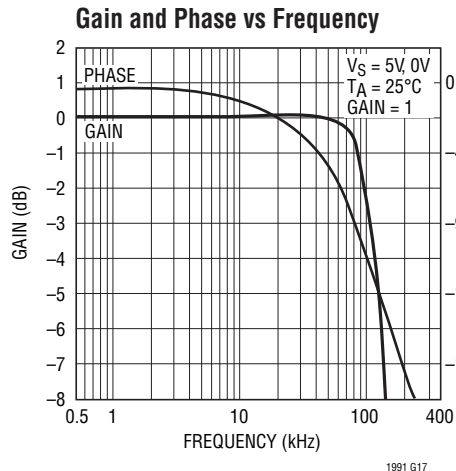
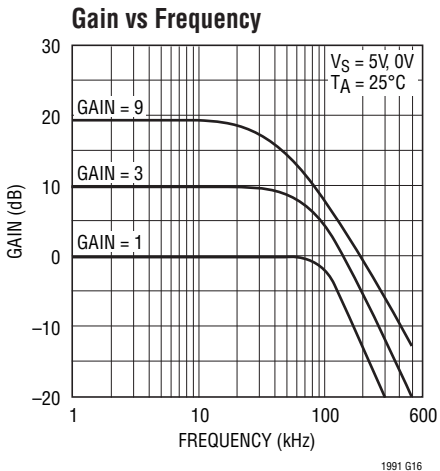
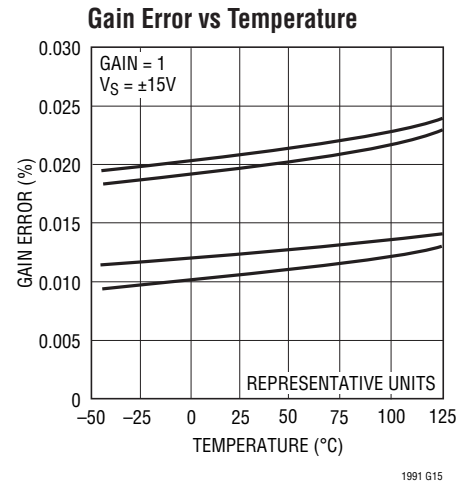
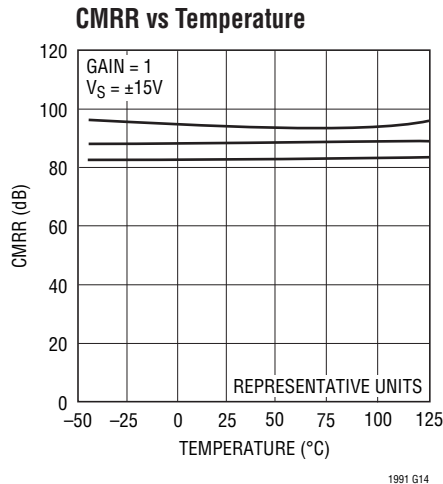
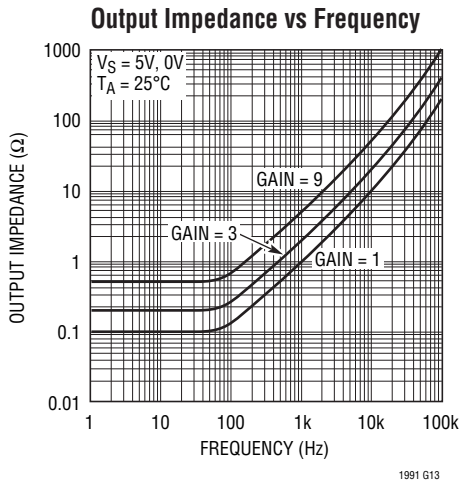
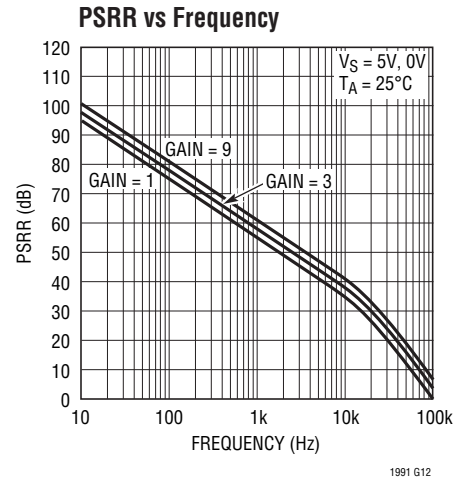
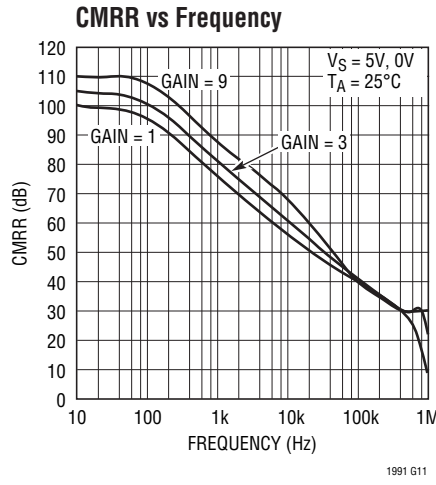
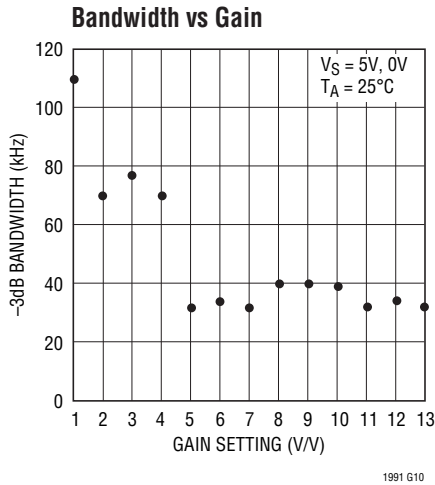

## TYPICAL PERFORMANCE CHARACTERISTICS

Small Signal Transient Response

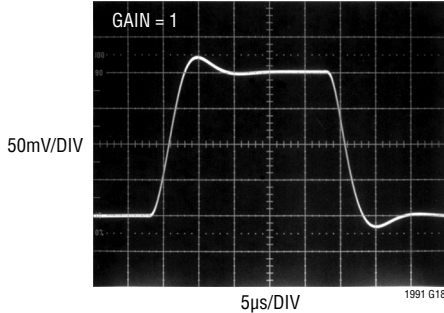

Small Signal Transient Response

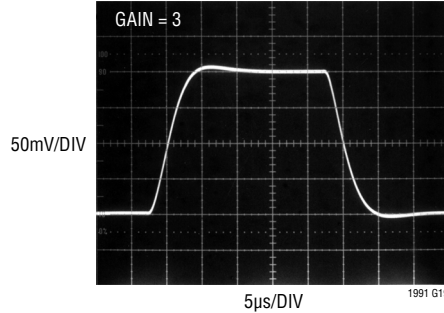

Small Signal Transient Response

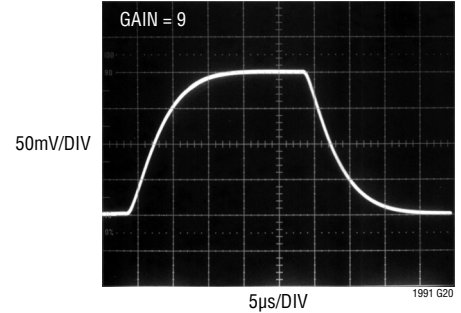

## PIN FUNCTIONS (Difference Amplifier Configuration)

**P1 (Pin 1):** Noninverting Gain-of-1 input. Connects a 450k internal resistor to the op amp's noninverting input.

**P3 (Pin 2):** Noninverting Gain-of-3 input. Connects a 150k internal resistor to the op amp's noninverting input.

**P9 (Pin 3):** Noninverting Gain-of-9 input. Connects a 50k internal resistor to the op amp's noninverting input.

**V<sub>EE</sub> (Pin 4):** Negative Power Supply. Can be either ground (in single supply applications), or a negative voltage (in split supply applications).

**REF (Pin 5):** Reference Input. Sets the output level when difference between inputs is zero. Connects a 450k internal resistor to the op amp's noninverting input.

**OUT (Pin 6):** Output.  $V_{OUT} = V_{REF} + 1 \cdot (V_{P1} - V_{M1}) + 3 \cdot (V_{P3} - V_{M3}) + 9 \cdot (V_{P9} - V_{M9})$ .

**V<sub>CC</sub> (Pin 7):** Positive Power Supply. Can be anything from 2.7V to 36V above the V<sub>EE</sub> voltage.

**M9 (Pin 8):** Inverting Gain-of-9 input. Connects a 50k internal resistor to the op amp's inverting input.

**M3 (Pin 9):** Inverting Gain-of-3 input. Connects a 150k internal resistor to the op amp's inverting input.

**M1 (Pin 10):** Inverting Gain-of-1 input. Connects a 450k internal resistor to the op amp's inverting input.

**Exposed Pad:** Must be soldered to PCB.

## BLOCK DIAGRAM

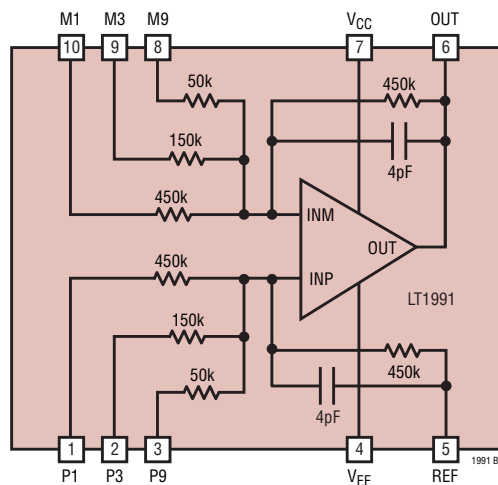

1991fh

## APPLICATIONS INFORMATION

### Introduction

The LT1991 may be the last op amp you ever have to stock. Because it provides you with several precision matched resistors, you can easily configure it into several different classical gain circuits without adding external components. The several pages of simple circuits in this data sheet demonstrate just how easy the LT1991 is to use. It can be configured into difference amplifiers, as well as into inverting and noninverting single ended amplifiers. The fact that the resistors and op amp are provided together in such a small package will often save you board space and reduce complexity for easy probing.

### The Op Amp

The op amp internal to the LT1991 is a precision device with 15 $\mu$ V typical offset voltage and 3nA input bias current. The input offset current is extremely low, so matching the source resistance seen by the op amp inputs will provide for the best output accuracy. The op amp inputs are not rail-to-rail, but extend to within 1.2V of  $V_{CC}$  and 1V of  $V_{EE}$ . For many configurations though, the chip inputs will function rail-to-rail because of effective attenuation to the +input. The output is truly rail-to-rail, getting to within 40mV of the supply rails. The gain bandwidth product of the op amp is about 560kHz. In noise gains of 2 or more, it is stable into capacitive loads up to 500pF. In noise gains below 2, it is stable into capacitive loads up to 100pF.

### The Resistors

The resistors internal to the LT1991 are very well matched SiChrome based elements protected with barrier metal. Although their absolute tolerance is fairly poor ( $\pm 30\%$ ), their matching is to within 0.04%. This allows the chip to achieve a CMRR of 75dB, and gain errors within 0.04%. The resistor values are 50k, 150k, and 2 of 450k, connected to each of the inputs. The resistors have power limitations of 1watt for the 450k resistors, 0.3watt for the 150k resistors and 0.5watt for the 50k resistors; however, in practice, power dissipation will be limited well below these values by the maximum voltage allowed on the input and REF pins. The 450k resistors connected to the M1 and P1 inputs are isolated from the substrate, and can therefore be taken beyond the supply voltages. The naming of the pins "P1," "P3," "P9," etc., is based on their relative

admittances. Because it has 9 times the admittance, the voltage applied to the P9 input has 9 times the effect of the voltage applied to the P1 input.

### Bandwidth

The bandwidth of the LT1991 will depend on the gain you select (or more accurately the noise gain resulting from the gain you select). In the lowest configurable gain of 1, the  $-3$ dB bandwidth is limited to 450kHz, with peaking of about 2dB at 280kHz. In the highest configurable gains, bandwidth is limited to 32kHz.

### Input Noise

The LT1991 input noise is dominated by the Johnson noise of the internal resistors ( $\sqrt{4kTR}$ ). Paralleling all four resistors to the +input gives a 32.1k $\Omega$  resistance, for 23nV/ $\sqrt{\text{Hz}}$  of voltage noise. The equivalent network on the -input gives another 23nV/ $\sqrt{\text{Hz}}$ , and taking their RMS sum gives a total 33nV/ $\sqrt{\text{Hz}}$  input referred noise floor. Output noise depends on configuration and noise gain.

### Input Resistance

The LT1991 input resistances vary with configuration, but once configured are apparent on inspection. Note that resistors connected to the op amp's -input are looking into a virtual ground, so they simply parallel. Any feedback resistance around the op amp does not contribute to input resistance. Resistors connected to the op amp's +input are looking into a high impedance, so they add as parallel or series depending on how they are connected, and whether or not some of them are grounded. The op amp +input itself presents a very high G $\Omega$  impedance. In the classical noninverting op amp configuration, the LT1991 presents the high input impedance of the op amp, as is usual for the noninverting case.

### Common Mode Input Voltage Range

The LT1991 valid common mode input range is limited by three factors:

1. Maximum allowed voltage on the pins
2. The input voltage range of the internal op amp
3. Valid output voltage

## APPLICATIONS INFORMATION

The maximum voltage allowed on the P3, M3, P9, and M9 inputs includes the positive and negative supply plus a diode drop. These pins should not be driven more than 0.2V outside of the supply rails. This is because they are connected through diodes to internal manufacturing post-package trim circuitry, and through a substrate diode to  $V_{EE}$ . If more than 10mA is allowed to flow through these pins, there is a risk that the LT1991 will be detrimmed or damaged. The P1 and M1 inputs do not have clamp diodes or substrate diodes or trim circuitry and can be taken well outside the supply rails. The maximum allowed voltage on the P1 and M1 pins is  $\pm 60V$ .

The input voltage range of the internal op amp extends to within 1.2V of  $V_{CC}$  and 1V of  $V_{EE}$ . The voltage at which the op amp inputs common mode is determined by the voltage at the op amp's +input, and this is determined by the voltages on pins P1, P3, P9 and REF (see "Calculating Input Voltage Range" section). This is true provided that the op amp is functioning and feedback is maintaining the inputs at the same voltage, which brings us to the third requirement.

For valid circuit function, the op amp output must not be clipped. The output will clip if the input signals are attempting to force it to within 40mV of its supply voltages. This usually happens due to too large a signal level, but it can also occur with zero input differential and must therefore be included as an example of a common mode problem. Consider Figure 1. This shows the LT1991 configured

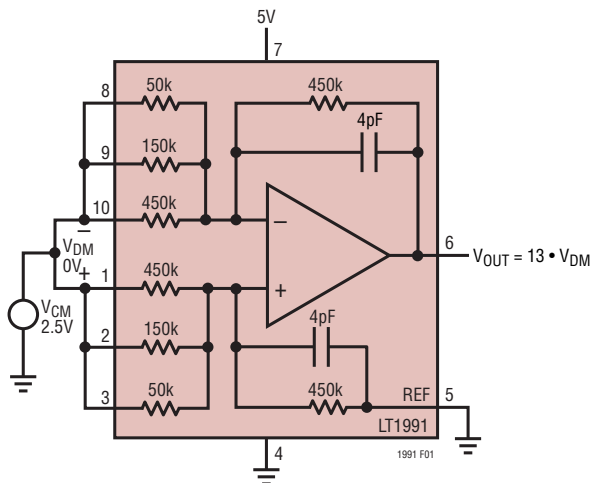

**Figure 1. Difference Amplifier Cannot Produce 0V on a Single Supply. Provide a Negative Supply, or Raise Pin 5, or Provide 4mV of  $V_{DM}$**

as a gain of 13 difference amplifier on a single supply with the output REF connected to ground. This is a great circuit, but it does not support  $V_{DM} = 0V$  at any common mode because the output clips into ground while trying to produce  $0V_{OUT}$ . It can be fixed simply by declaring the valid input differential range not to extend below +4mV, or by elevating the REF pin above 40mV, or by providing a negative supply.

### Calculating Input Voltage Range

Figure 2 shows the LT1991 in the generalized case of a difference amplifier, with the inputs shorted for the common mode calculation. The values of  $R_F$  and  $R_G$  are dictated by how the P inputs and REF pin are connected. By superposition we can write:

$$V_{INT} = V_{EXT} \cdot (R_F / (R_F + R_G)) + V_{REF} \cdot (R_G / (R_F + R_G))$$

Or, solving for  $V_{EXT}$ :

$$V_{EXT} = V_{INT} \cdot (1 + R_G / R_F) - V_{REF} \cdot R_G / R_F$$

But valid  $V_{INT}$  voltages are limited to  $V_{CC} - 1.2V$  and  $V_{EE} + 1V$ , so:

$$MAX V_{EXT} = (V_{CC} - 1.2) \cdot (1 + R_G / R_F) - V_{REF} \cdot R_G / R_F$$

and:

$$MIN V_{EXT} = (V_{EE} + 1) \cdot (1 + R_G / R_F) - V_{REF} \cdot R_G / R_F$$

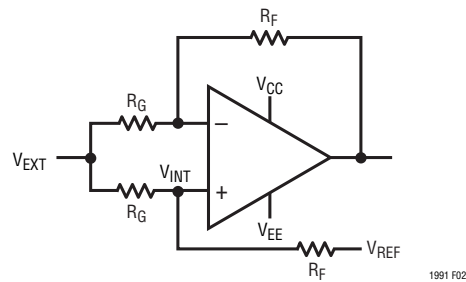

**Figure 2. Calculating CM Input Voltage Range**

These two voltages represent the high and low extremes of the common mode input range, if the other limits have not already been exceeded (1 and 3, above). In most cases, the inverting inputs M1 through M9 can be taken further than these two extremes because doing this does not move the op amp input common mode. To calculate the limit on this additional range, see Figure 3. Note that,

## APPLICATIONS INFORMATION

with  $V_{MORE} = 0$ , the op amp output is at  $V_{REF}$ . From the max  $V_{EXT}$  (the high cm limit), as  $V_{MORE}$  goes positive, the op amp output will go more negative from  $V_{REF}$  by the amount  $V_{MORE} \cdot R_F/R_G$ , so:

$$V_{OUT} = V_{REF} - V_{MORE} \cdot R_F/R_G$$

Or:

$$V_{MORE} = (V_{REF} - V_{OUT}) \cdot R_G/R_F$$

The most negative that  $V_{OUT}$  can go is  $V_{EE} + 0.04V$ , so:

$$\text{Max } V_{MORE} = (V_{REF} - V_{EE} - 0.04V) \cdot R_G/R_F$$

(should be positive)

The situation where this function is negative, and therefore problematic, when  $V_{REF} = 0$  and  $V_{EE} = 0$ , has already been dealt with in Figure 1. The strength of the equation is demonstrated in that it provides the three solutions suggested in Figure 1: raise  $V_{REF}$ , lower  $V_{EE}$ , or provide some negative  $V_{MORE}$ .

Likewise, from the lower common mode extreme, making the negative input more negative will raise the output voltage, limited by  $V_{CC} - 0.04V$ .

$$\text{MIN } V_{MORE} = (V_{REF} - V_{CC} + 0.04V) \cdot R_G/R_F$$

(should be negative)

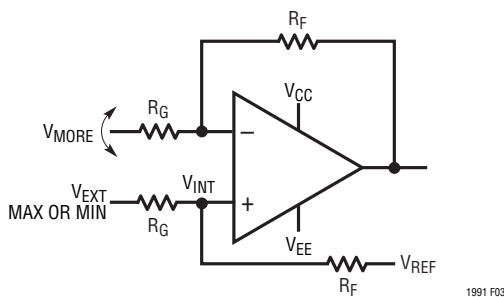

**Figure 3. Calculating Additional Voltage Range of Inverting Inputs**

Again, the additional input range calculated here is only available provided the other remaining constraint is not violated, the maximum voltage allowed on the pin.

### The Classical Noninverting Amplifier: High Input Z

Perhaps the most common op amp configuration is the noninverting amplifier. Figure 4 shows the textbook

representation of the circuit on the top. The LT1991 is shown on the bottom configured in a precision gain of 5.5. One of the benefits of the noninverting op amp configuration is that the input impedance is extremely high. The LT1991 maintains this benefit. Given the finite number of available feedback resistors in the LT1991, the number of gain configurations is also finite. The complete list of such Hi-Z input noninverting gain configurations is shown in Table 1. Many of these are also represented in Figure 5 in schematic form. Note that the P-side resistor inputs have been connected so as to match the source impedance seen by the internal op amp inputs. Note also that gain and noise gain are identical, for optimal precision.

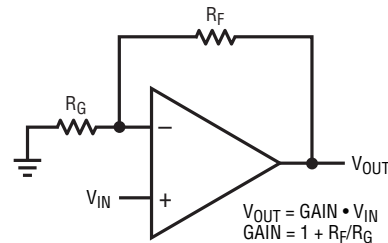

CLASSICAL NONINVERTING OP AMP CONFIGURATION. YOU PROVIDE THE RESISTORS.

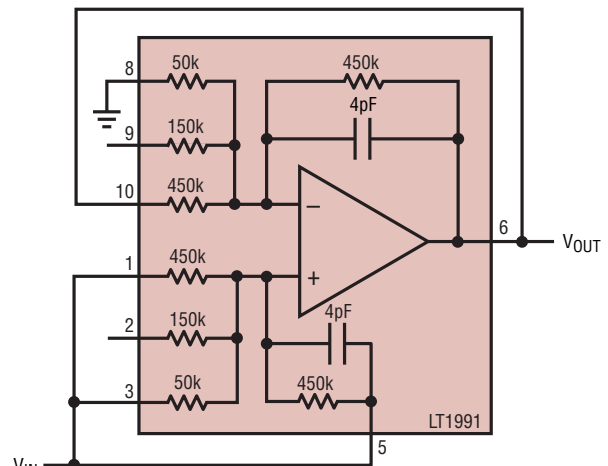

CLASSICAL NONINVERTING OP AMP CONFIGURATION IMPLEMENTED WITH LT1991.  $R_F = 225k$ ,  $R_G = 50k$ , GAIN = 5.5.

GAIN IS ACHIEVED BY GROUNDING, FLOATING OR FEEDING BACK THE AVAILABLE RESISTORS TO ARRIVE AT DESIRED  $R_F$  AND  $R_G$ .

WE PROVIDE YOU WITH <0.1% RESISTORS.

1991 F04

**Figure 4. The LT1991 as a Classical Noninverting Op Amp**

## APPLICATIONS INFORMATION

**Table 1. Configuring the M Pins for Simple Noninverting Gains.**  
The P Inputs are driven as shown in the examples on the next page

Gain	M9, M3, M1 Connection		
	M9	M3	M1
1	Output	Output	Output
1.077	Output	Output	Ground
1.1	Output	Float	Ground
1.25	Float	Output	Ground
1.273	Output	Ground	Output
1.3	Output	Ground	Float
1.4	Output	Ground	Ground
2	Float	Float	Ground
2.5	Float	Ground	Output
2.8	Ground	Output	Output
3.25	Ground	Output	Float
3.5	Ground	Output	Ground
4	Float	Ground	Float
5	Float	Ground	Ground
5.5	Ground	Float	Output
7	Ground	Ground	Output
10	Ground	Float	Float
11	Ground	Float	Ground
13	Ground	Ground	Float
14	Ground	Ground	Ground

APPLICATIONS INFORMATION

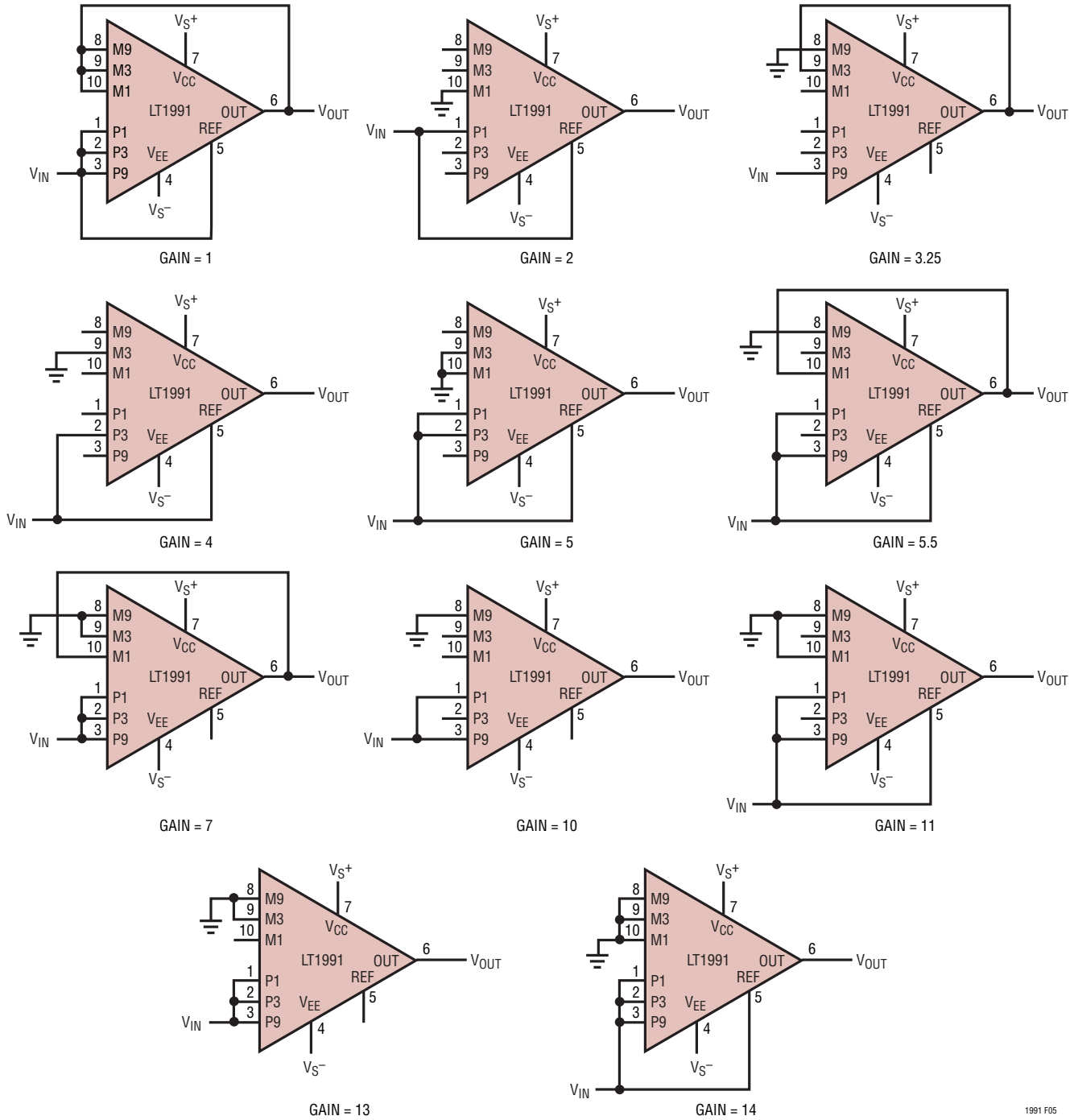

1991 F05

Figure 5. Some Implementations of Classical Noninverting Gains Using the LT1991. High Input Z is Maintained

# APPLICATIONS INFORMATION

## Attenuation Using the P Input Resistors

Attenuation happens as a matter of fact in difference amplifier configurations, but it is also used for reducing peak signal level or improving input common mode range even in single ended systems. When signal conditioning indicates a need for attenuation, the LT1991 resistors are ready at hand. The four precision resistors can provide several attenuation levels, and these are tabulated in Table 2 as a design reference.

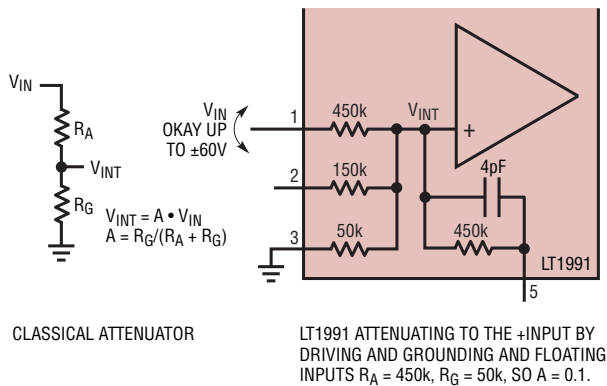

Figure 6. LT1991 Provides for Easy Attenuation to the Op Amp's +Input. The P1 Input Can Be Taken Well Outside of the Supplies

Because the attenuations and the noninverting gains are set independently, they can be combined. This provides high gain resolution, about 340 unique gains between 0.077 and 14, as plotted in Figure 7. This is too large a number to tabulate, but the designer can calculate achievable gain by taking the vector product of the gains and attenuations in Tables 1 and 2, and seeking the best match. Average gain resolution is 1.5%, with a worst-case of 7%.

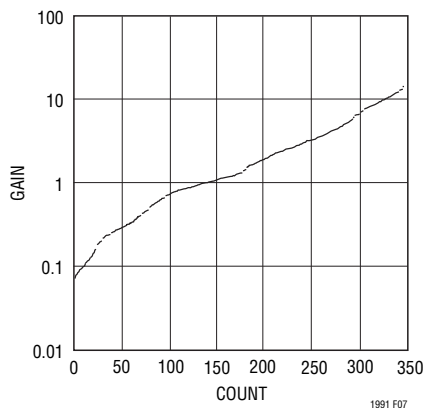

Figure 7. Over 346 Unique Gain Settings Achievable with the LT1991 by Combining Attenuation with Noninverting Gain

Table 2. Configuring the P Pins for Various Attenuations. Those Shown in Bold Are Functional Even When the Input Drive Exceeds the Supplies.

A	P9, P3, P1, REF Connection			
	P9	P3	P1	REF
<b>0.0714</b>	Ground	Ground	<b>Drive</b>	Ground
<b>0.0769</b>	Ground	Ground	<b>Drive</b>	Float
<b>0.0909</b>	Ground	Float	<b>Drive</b>	Ground
<b>0.1</b>	Ground	Float	<b>Drive</b>	Float
0.143	Ground	Ground	Drive	Drive
0.182	Ground	Float	Drive	Drive
<b>0.2</b>	Float	Ground	<b>Drive</b>	Ground
0.214	Ground	Drive	Ground	Ground
0.231	Ground	Drive	Float	Ground
<b>0.25</b>	Float	Ground	<b>Drive</b>	Float
0.286	Ground	Drive	Drive	Ground
0.308	Ground	Drive	Drive	Float
0.357	Ground	Drive	Drive	Drive
0.4	Float	Ground	Drive	Drive
<b>0.5</b>	Float	Float	<b>Drive</b>	Ground
0.6	Float	Drive	Ground	Ground
0.643	Drive	Ground	Ground	Ground
0.692	Drive	Ground	Float	Ground
0.714	Drive	Ground	Drive	Ground
0.75	Float	Drive	Float	Ground
0.769	Drive	Ground	Drive	Float
0.786	Drive	Ground	Drive	Drive
0.8	Float	Drive	Drive	Ground
0.818	Drive	Float	Ground	Ground
0.857	Drive	Drive	Ground	Ground
0.9	Drive	Float	Float	Ground
0.909	Drive	Float	Drive	Ground
0.923	Drive	Drive	Float	Ground
0.929	Drive	Drive	Drive	Ground
1	Drive	Drive	Drive	Drive

# APPLICATIONS INFORMATION

## Inverting Configuration

The inverting amplifier, shown in Figure 8, is another classical op amp configuration. The circuit is actually identical to the noninverting amplifier of Figure 4, except that  $V_{IN}$  and GND have been swapped. The list of available gains is shown in Table 3, and some of the circuits are shown in Figure 9. Noise gain is  $1+|Gain|$ , as is the usual case for inverting amplifiers. Again, for the best DC performance, match the source impedance seen by the op amp inputs.

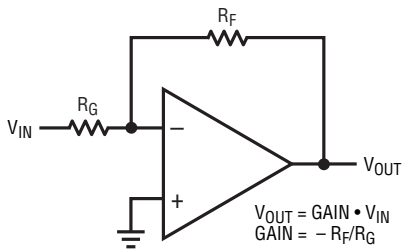

CLASSICAL INVERTING OP AMP CONFIGURATION. YOU PROVIDE THE RESISTORS.

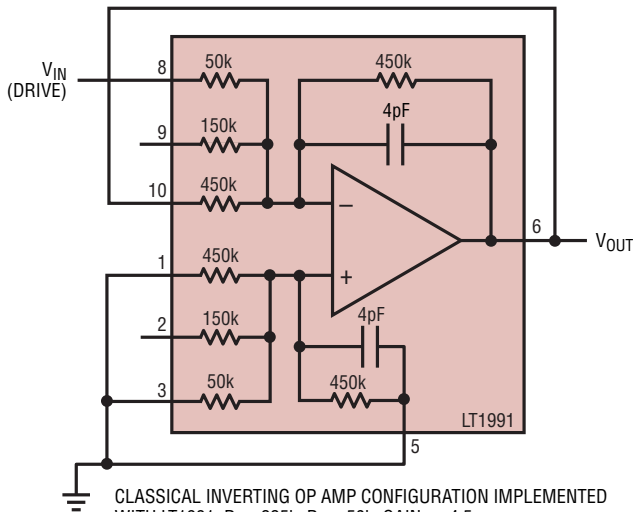

CLASSICAL INVERTING OP AMP CONFIGURATION IMPLEMENTED WITH LT1991.  $R_F = 225k$ ,  $R_G = 50k$ ,  $GAIN = -4.5$ .

GAIN IS ACHIEVED BY GROUNDING, FLOATING OR FEEDING BACK THE AVAILABLE RESISTORS TO ARRIVE AT DESIRED  $R_F$  AND  $R_G$ .

WE PROVIDE YOU WITH <0.1% RESISTORS.

1991 F08

Table 3. Configuring the M Pins for Simple Inverting Gains

Gain	M9, M3, M1 Connection		
	M9	M3	M1
-0.077	Output	Output	Drive
-0.1	Output	Float	Drive
-0.25	Float	Output	Drive
-0.273	Output	Drive	Output
-0.3	Output	Drive	Float
-0.4	Output	Drive	Drive
-1	Float	Float	Drive
-1.5	Float	Drive	Output
-1.8	Drive	Output	Output
-2.25	Drive	Output	Float
-2.5	Drive	Output	Drive
-3	Float	Drive	Float
-4	Float	Drive	Drive
-4.5	Drive	Float	Output
-6	Drive	Drive	Output
-9	Drive	Float	Float
-10	Drive	Float	Drive
-12	Drive	Drive	Float
-13	Drive	Drive	Drive

Figure 8. The LT1991 as a Classical Inverting Op Amp. Note the Circuit Is Identical to the Noninverting Amplifier, Except that  $V_{IN}$  and Ground Have Been Swapped

# APPLICATIONS INFORMATION

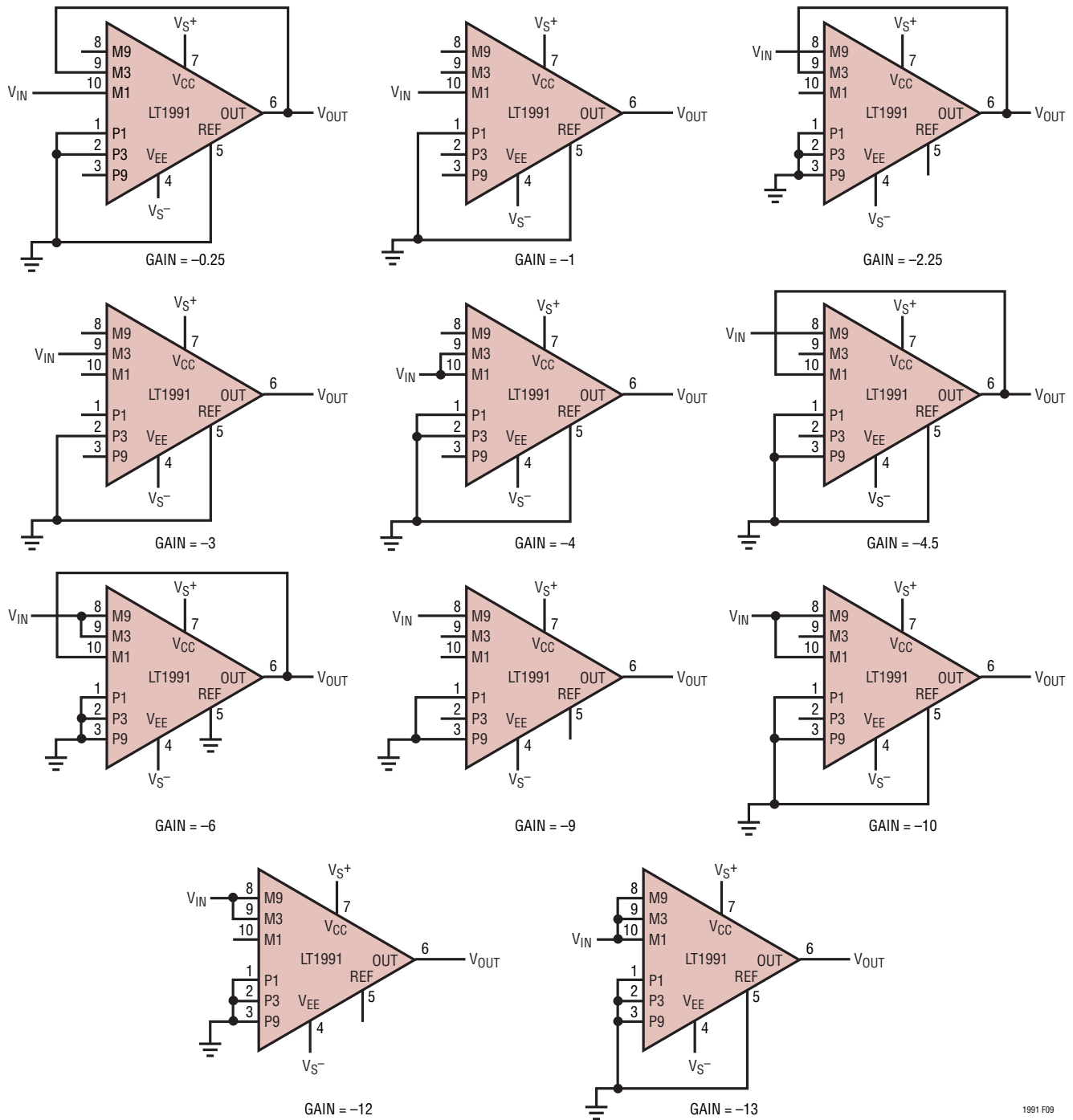

**Figure 9. It Is Simple to Get Precision Inverting Gains with the LT1991. Input Impedance Varies from 45kΩ (Gain = -13) to 450kΩ (Gain = -1)**

1991 F09

## APPLICATIONS INFORMATION

### Difference Amplifiers

The resistors in the LT1991 allow it to easily make difference amplifiers also. Figure 10 shows the basic 4-resistor difference amplifier and the LT1991. A difference gain of 3 is shown, but notice the effect of the additional dashed connections. By connecting the 450k resistors in parallel, the gain is reduced by a factor of 2. Of course, with so many resistors, there are many possible gains. Table 4 shows the difference gains and how they are achieved. Note that, as for inverting amplifiers, the noise gain is 1 more than the signal gain.

**Table 4. Connections Giving Difference Gains for the LT1991**

Gain	V <sub>IN</sub> <sup>+</sup>	V <sub>IN</sub> <sup>-</sup>	Output	GND (REF)
0.077	P1	M1	M3, M9	P3, P9
0.1	P1	M1	M9	P9
0.25	P1	M1	M3	P3
0.273	P3	M3	M1, M9	P1, P9
0.3	P3	M3	M9	P9
0.4	P1, P3	M1, M3	M9	P9
1	P1	M1		
1.5	P3	M3	M1	P1
1.8	P9	M9	M1, M3	P1, P3
2.25	P9	M9	M3	P3
2.5	P1, P9	M1, M9	M3	P3
3	P3	M3		
4	P1, P3	M1, M3		
4.5	P9	M9	M1	P1
6	P3, P9	M3, M9	M1	P1
9	P9	M9		
10	P1, P9	M1, M9		
12	P3, P9	M3, M9		
13	P1, P3, P9	M1, M3, M9		

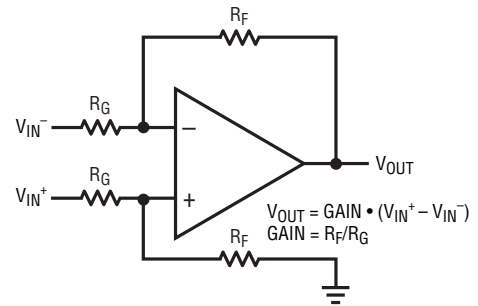

CLASSICAL DIFFERENCE AMPLIFIER USING THE LT1991

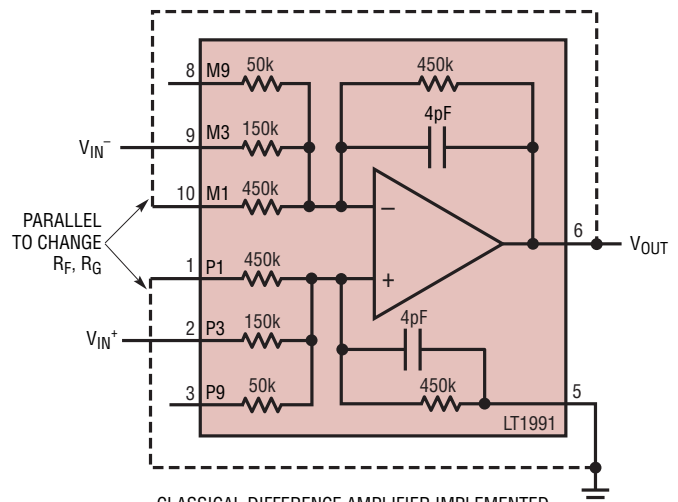

CLASSICAL DIFFERENCE AMPLIFIER IMPLEMENTED WITH LT1991. R<sub>F</sub> = 450k, R<sub>G</sub> = 150k, GAIN = 3.

ADDING THE DASHED CONNECTIONS CONNECTS THE TWO 450k RESISTORS IN PARALLEL, SO R<sub>F</sub> IS REDUCED TO 225k. GAIN BECOMES 225k/150k = 1.5.

1991 F10

**Figure 10. Difference Amplifier Using the LT1991. Gain Is Set Simply by Connecting the Correct Resistors or Combinations of Resistors. Gain of 3 Is Shown, with Dashed Lines Modifying It to Gain of 1.5. Noise Gain Is Optimal**

APPLICATIONS INFORMATION

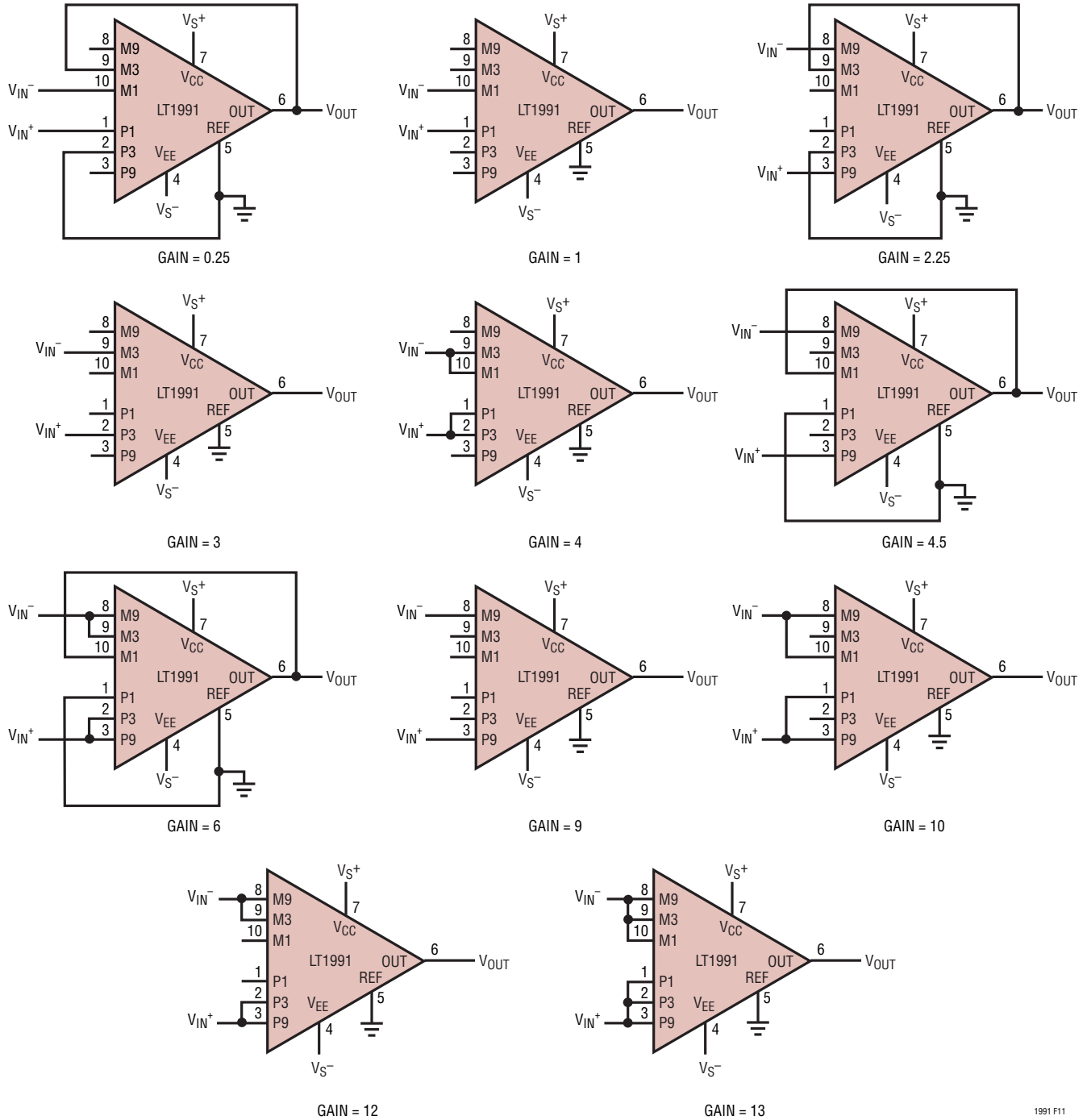

Figure 11. Many Different Gains Are Achievable Just by Strapping the Pins

1991 F11

APPLICATIONS INFORMATION

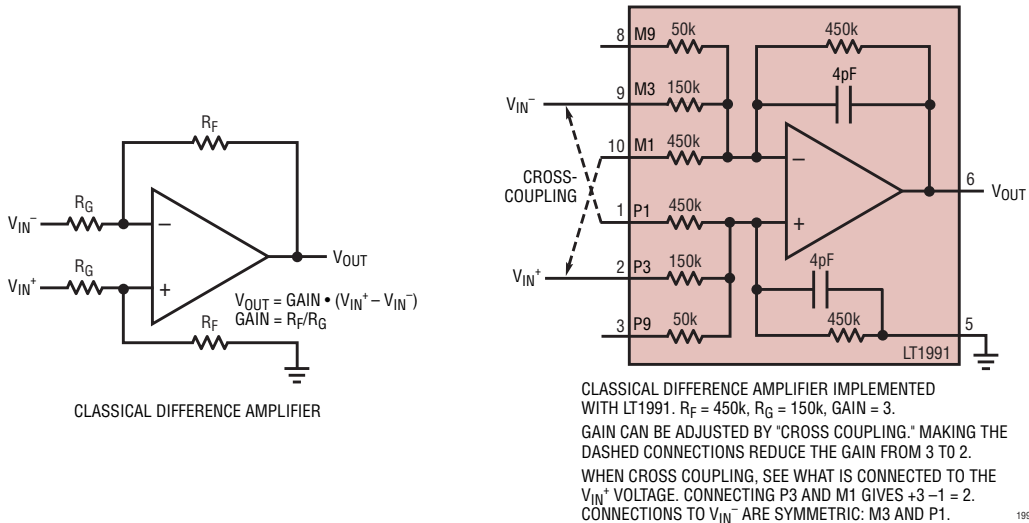

Figure 12. Another Method of Selecting Difference Gain Is "Cross-Coupling." The Additional Method Means the LT1991 Provides All Integer Gains from 1 to 13

Difference Amplifier: Additional Integer Gains Using Cross-Coupling

Figure 12 shows the basic difference amplifier as well as the LT1991 in a difference gain of 3. But notice the effect of the additional dashed connections. This is referred to as "cross-coupling" and has the effect of reducing the differential gain from 3 to 2. Using this method, additional integer gains are achievable, as shown in Table 5 below, so that all integer gains from 1 to 13 are achieved with the LT1991. Note that the equations can be written by inspection from the  $V_{IN}^+$  connections, and that the  $V_{IN}^-$  connections are simply the opposite (swap P for M and M for P). Noise gain, bandwidth, and input impedance specifications for the various cases are also tabulated, as these are not obvious. Schematics are provided in Figure 13.

Table 5. Connections Using Cross-Coupling. Note That Equations Can Be Written by Inspection of the  $V_{IN}^+$  Column

Gain	$V_{IN}^+$	$V_{IN}^-$	Equation	Noise Gain	-3dB BW kHz	$R_{IN}^+$ Typ k $\Omega$	$R_{IN}^-$ Typ k $\Omega$
2	P3, M1	M3, P1	$3 - 1$	5	70	281	141
5	P9, M3, M1	M9, P3, P1	$9 - 3 - 1$	14	32	97	49
6*	P9, M3	M9, P3	$9 - 3$	13	35	122	49
7	P9, P1, M3	M9, M1, P3	$9 + 1 - 3$	14	32	121	44
8	P9, M1	M9, P1	$9 - 1$	11	38	248	50
11	P9, P3, M1	M9, M3, P1	$9 + 3 - 1$	14	32	242	37

\*Gain of 6 is better implemented as shown previously, but is included here for completeness.

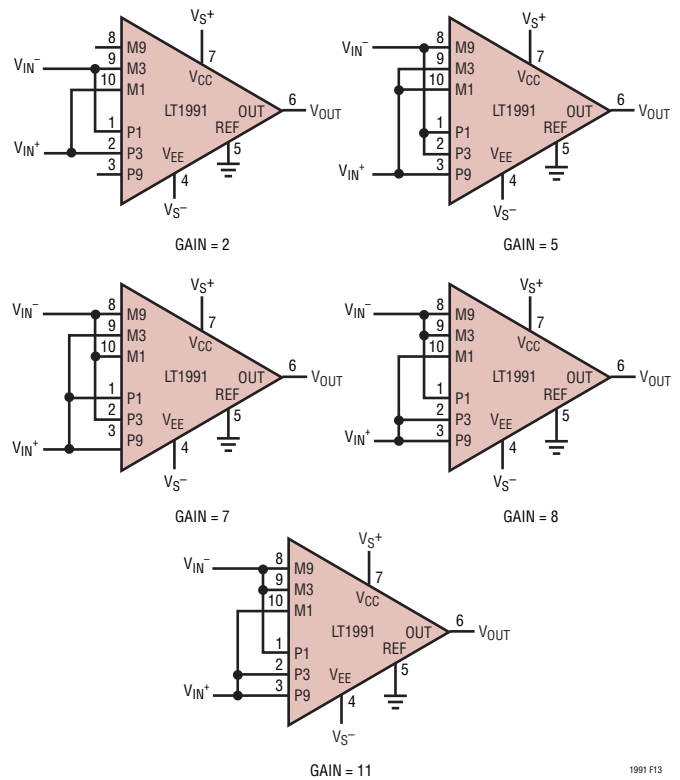

Figure 13. Integer Gain Difference Amplifiers Using Cross-Coupling

## APPLICATIONS INFORMATION

### High Voltage CM Difference Amplifiers

This class of difference amplifier remains to be discussed. Figure 14 shows the basic circuit on the top. The effective input voltage range of the circuit is extended by the fact that resistors  $R_T$  attenuate the common mode voltage seen by the op amp inputs. For the LT1991, the most useful resistors for  $R_G$  are the M1 and P1 450k $\Omega$  resistors, because they do not have diode clamps to the supplies and therefore can be taken outside the supplies. As before, the input CM of the op amp is the limiting factor and is set by the voltage at the op amp +input,  $V_{INT}$ . By superposition we can write:

$$V_{INT} = V_{EXT} \cdot (R_F || R_T) / (R_G + R_F || R_T) + V_{REF} \cdot (R_G || R_T) / (R_F + R_G || R_T) + V_{TERM} \cdot (R_F || R_G) / (R_T + R_F || R_G)$$

Solving for  $V_{EXT}$ :

$$V_{EXT} = (1 + R_G / (R_F || R_T)) \cdot (V_{INT} - V_{REF} \cdot (R_G || R_T) / (R_F + R_G || R_T)) - V_{TERM} \cdot (R_F || R_G) / (R_T + R_F || R_G)$$

Given the values of the resistors in the LT1991, this equation has been simplified and evaluated, and the resulting equations provided in Table 6. As before, substituting  $V_{CC} - 1.2$  and  $V_{EE} + 1$  for  $V_{LIM}$  will give the valid upper and lower common mode extremes respectively. Following are sample calculations for the case shown in Figure 14, right-hand side. Note that P9 and M9 are terminated so row 3 of Table 6 provides the equation:

$$\begin{aligned} \text{MAX } V_{EXT} &= 11 \cdot (V_{CC} - 1.2V) - V_{REF} - 9 \cdot V_{TERM} \\ &= 11 \cdot (10.8V) - 2.5 - 9 \cdot 12 = 8.3V \end{aligned}$$

and:

$$\begin{aligned} \text{MIN } V_{EXT} &= 11 \cdot (V_{EE} + 1V) - V_{REF} - 9 \cdot V_{TERM} \\ &= 11 \cdot (1V) - 2.5 - 9 \cdot 12 = -99.5V \end{aligned}$$

but this exceeds the 60V absolute maximum rating of the P1, M1 pins, so  $-60V$  becomes the de facto negative common mode limit. Several more examples of high CM circuits are shown in Figures 15, 16, 17 for various supplies.

Table 6. HighV CM Connections Giving Difference Gains for the LT1991

Gain	$V_{IN}^+$	$V_{IN}^-$	$R_T$	Noise Gain	Max, Min $V_{EXT}$ (Substitute $V_{CC} - 1.2$ , $V_{EE} + 1$ for $V_{LIM}$ )
1	P1	M1		2	$2 \cdot V_{LIM} - V_{REF}$
1	P1	M1	P3, M3	5	$5 \cdot V_{LIM} - V_{REF} - 3 \cdot V_{TERM}$
1	P1	M1	P9, M9	11	$11 \cdot V_{LIM} - V_{REF} - 9 \cdot V_{TERM}$
1	P1	M1	P3  P9 M3  M9	14	$14 \cdot V_{LIM} - V_{REF} - 12 \cdot V_{TERM}$

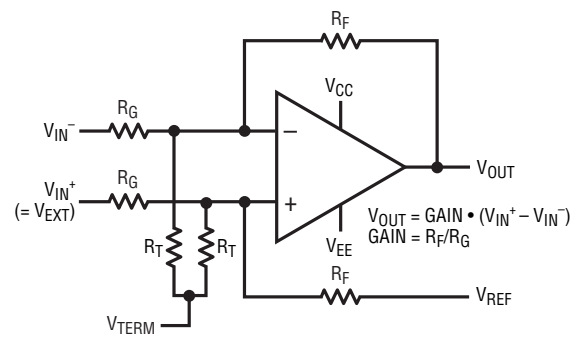

HIGH CM VOLTAGE DIFFERENCE AMPLIFIER

INPUT CM TO OP AMP IS ATTENUATED BY RESISTORS  $R_T$  CONNECTED TO  $V_{TERM}$ .

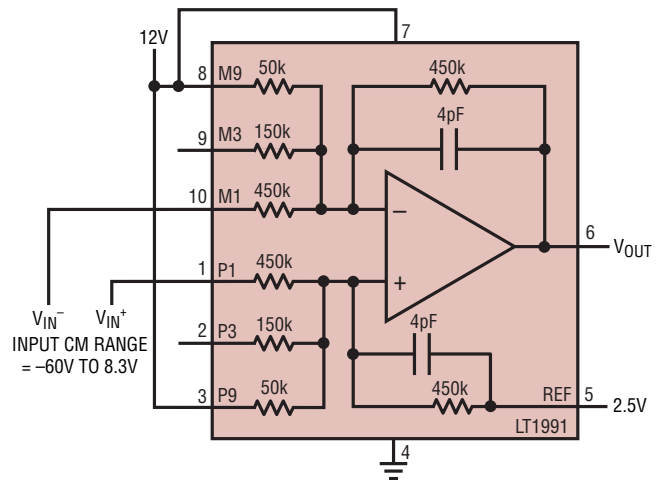

HIGH NEGATIVE CM VOLTAGE DIFFERENCE AMPLIFIER IMPLEMENTED WITH LT1991.

$R_F = 450k$ ,  $R_G = 450k$ ,  $R_T = 50k$ , GAIN = 1

$V_{TERM} = V_{CC} = 12V$ ,  $V_{REF} = 2.5V$ ,  $V_{EE} = \text{GROUND}$ .

1991 F14

Figure 14. Extending CM Input Range

APPLICATIONS INFORMATION

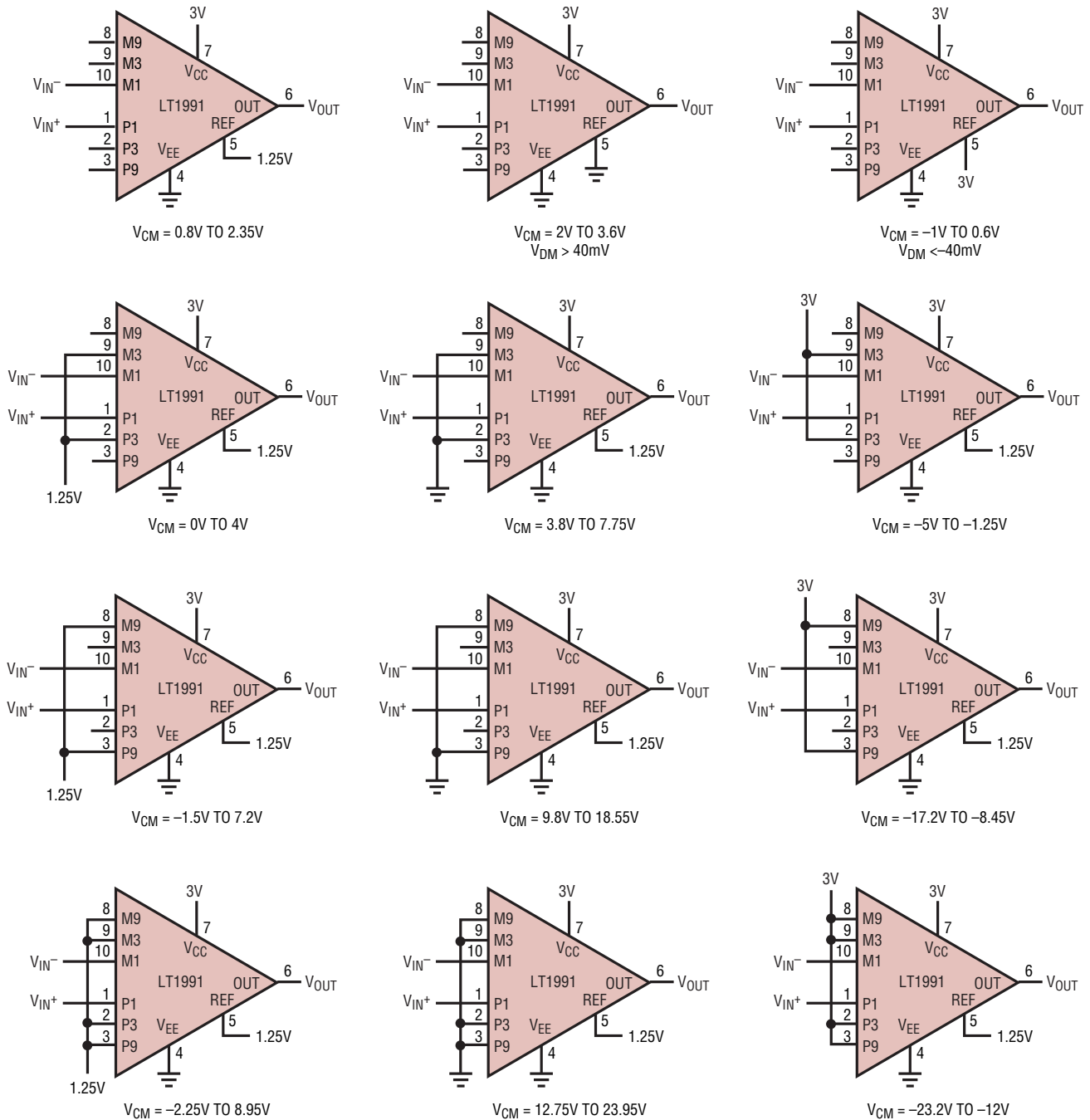

1991 F15

Figure 15. Common Mode Ranges for Various LT1991 Configurations on  $V_S = 3V, 0V$ ; with Gain = 1

APPLICATIONS INFORMATION

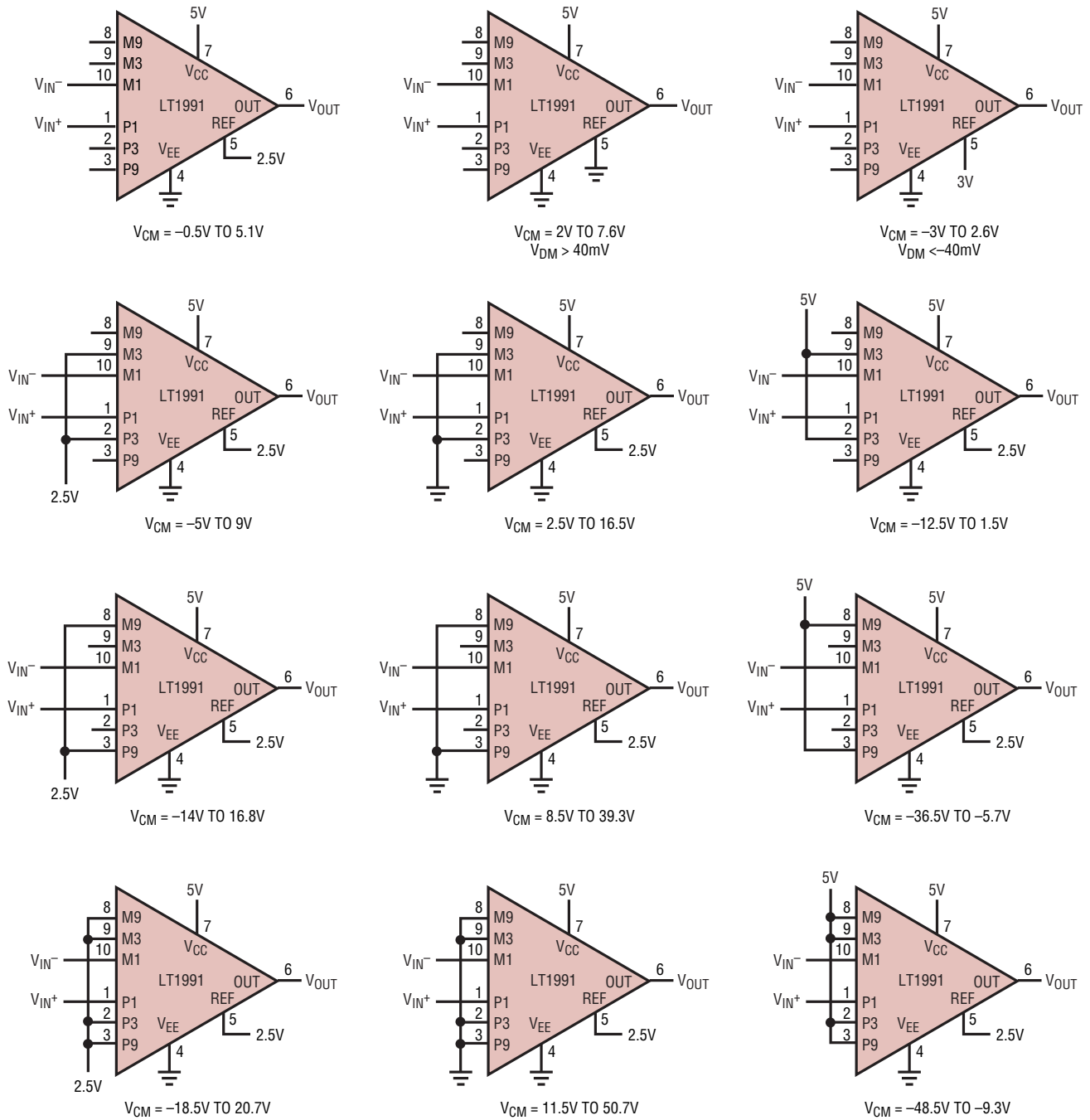
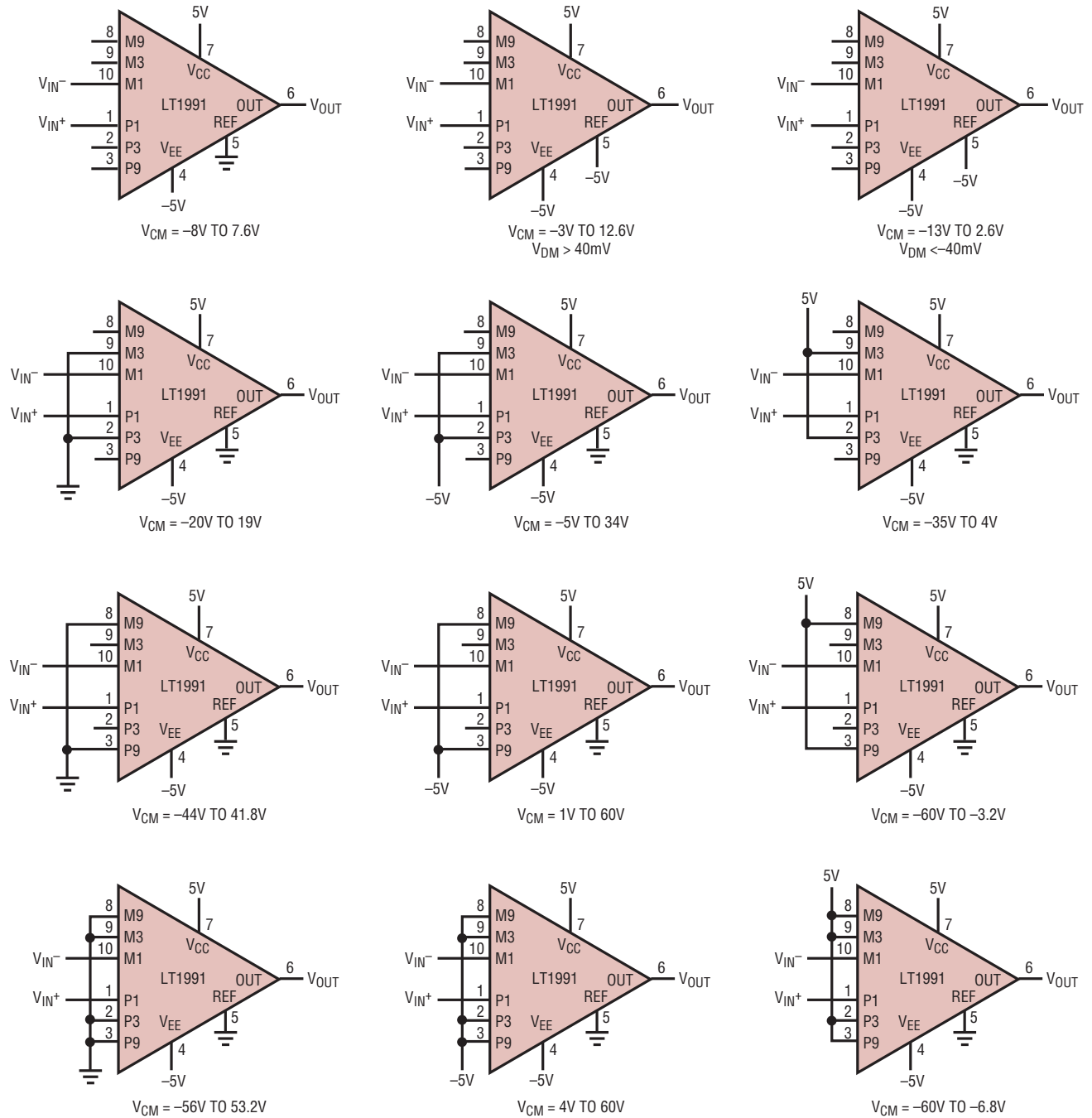

Figure 16. Common Mode Ranges for Various LT1991 Configurations on  $V_S = 5V, 0V$ ; with Gain = 1

1991 F16

APPLICATIONS INFORMATION



1991 F17

Figure 17. Common Mode Ranges for Various LT1991 Configurations on  $V_S = \pm 5V$ , with Gain = 1

# TYPICAL APPLICATIONS

## Micropower $A_V = 10$ Instrumentation Amplifier

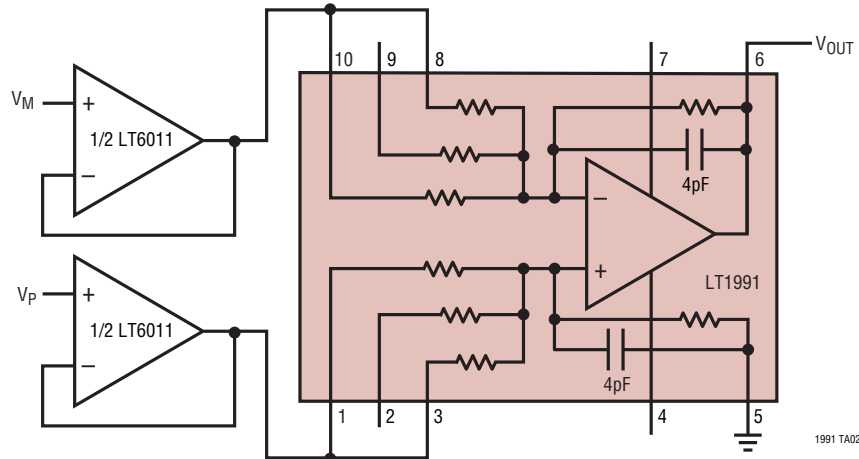

1991 TA02

# PACKAGE DESCRIPTION

Please refer to <http://www.linear.com/designtools/packaging/> for the most recent package drawings.

### DD Package 10-Lead Plastic DFN (3mm × 3mm) (Reference LTC DWG # 05-08-1699 Rev C)

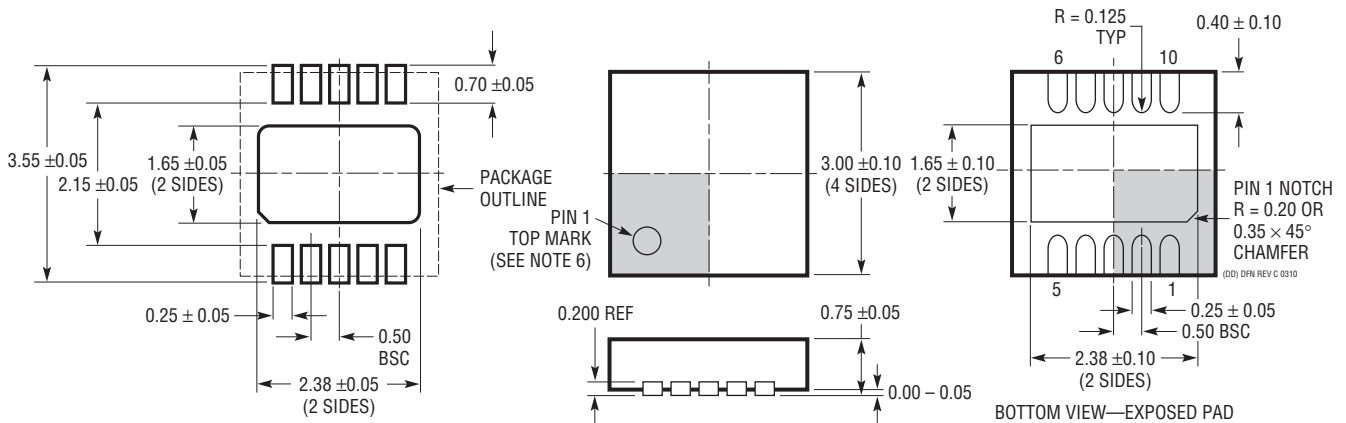

#### RECOMMENDED SOLDER PAD PITCH AND DIMENSIONS

##### NOTE:

1. DRAWING TO BE MADE A JEDEC PACKAGE OUTLINE M0-229 VARIATION OF (WEED-2).  
CHECK THE LTC WEBSITE DATA SHEET FOR CURRENT STATUS OF VARIATION ASSIGNMENT
2. DRAWING NOT TO SCALE
3. ALL DIMENSIONS ARE IN MILLIMETERS
4. DIMENSIONS OF EXPOSED PAD ON BOTTOM OF PACKAGE DO NOT INCLUDE MOLD FLASH. MOLD FLASH, IF PRESENT, SHALL NOT EXCEED 0.15mm ON ANY SIDE
5. EXPOSED PAD SHALL BE SOLDER PLATED
6. SHADED AREA IS ONLY A REFERENCE FOR PIN 1 LOCATION ON THE TOP AND BOTTOM OF PACKAGE

# PACKAGE DESCRIPTION

Please refer to <http://www.linear.com/designtools/packaging/> for the most recent package drawings.

**MS Package**  
**10-Lead Plastic MSOP**  
 (Reference LTC DWG # 05-08-1661 Rev E)

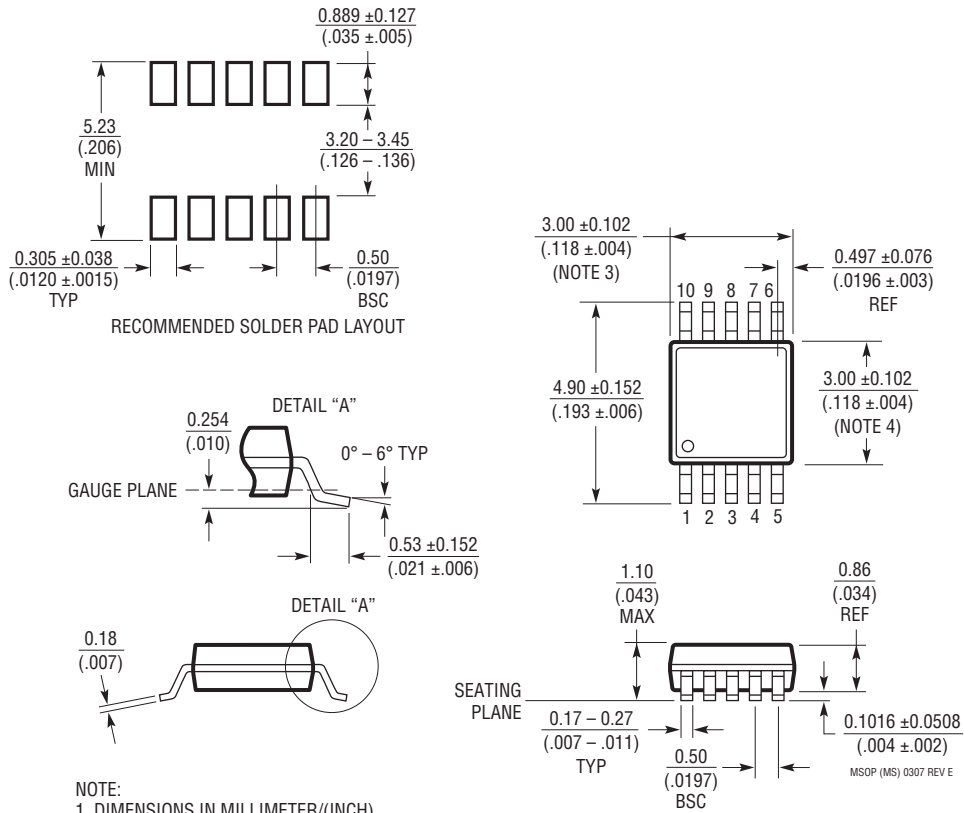

- NOTE:
1. DIMENSIONS IN MILLIMETER/(INCH)
  2. DRAWING NOT TO SCALE
  3. DIMENSION DOES NOT INCLUDE MOLD FLASH, PROTRUSIONS OR GATE BURRS.  
MOLD FLASH, PROTRUSIONS OR GATE BURRS SHALL NOT EXCEED  $0.152\text{mm}$  ( $.006$ " ) PER SIDE
  4. DIMENSION DOES NOT INCLUDE INTERLEAD FLASH OR PROTRUSIONS.  
INTERLEAD FLASH OR PROTRUSIONS SHALL NOT EXCEED  $0.152\text{mm}$  ( $.006$ " ) PER SIDE
  5. LEAD COPLANARITY (BOTTOM OF LEADS AFTER FORMING) SHALL BE  $0.102\text{mm}$  ( $.004$ " ) MAX

**REVISION HISTORY** (Revision history begins at Rev H)

REV	DATE	DESCRIPTION	PAGE NUMBER
H	5/12	Corrected specified temperature range for C-grade parts in the Order Information table.	2
		Corrected $V_{CM} = -20V$ to $19V$ and $V_{CM} = -5V$ to $34V$ configurations in Figure 17.	24
		Updated Related Parts Table	28

## TYPICAL APPLICATION

### Bidirectional Current Source

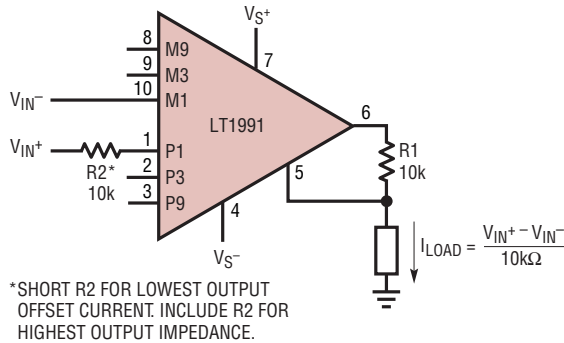

### Single Supply AC Coupled Amplifier

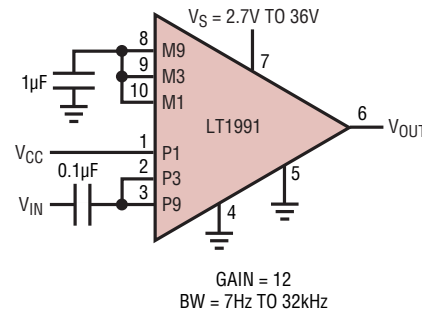

1991 TA03

### Ultra-Stable Precision Attenuator

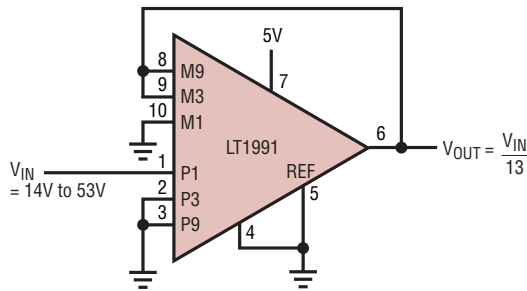

### Analog Level Adaptor

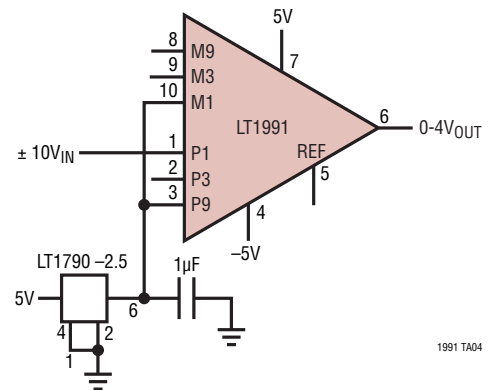

1991 TA04

## RELATED PARTS

PART NUMBER	DESCRIPTION	COMMENTS
LT1990	High Voltage, Gain Selectable Difference Amplifier	±250V Common Mode, Micropower, Pin Selectable Gain = 1, 10
LT1996	Precision Gain Selectable Difference Amplifier	Micropower, Pin Selectable Up to Gain = 118
LT1995	High Speed, Gain Selectable Difference Amplifier	30MHz, 1000V/µs, Pin Selectable Gain = -7 to 8
LT6010/LT6011/ LT6012	Single/Dual/Quad 135µA 14nV/√Hz Rail-to-Rail Out Precision Op Amp	Similar Op Amp Performance as Used in LT1991 Difference Amplifier
LT6013/LT6014	Single/Dual 145µA 8nV/√Hz Rail-to-Rail Out Precision Op Amp	Lower Noise $A_V \geq 5$ Version of LT1991 Type Op Amp
LTC6910-X	Programmable Gain Amplifiers	3 Gain Configurations, Rail-to-Rail Input and Output
LT1999	High Voltage Bidirectional Current Sense Amplifier	CMRR > 80dB at 100kHz
LT5400	Quad Matched Resistor Network	0.01% Matching, CMRR > 86dB